

Joseph Lstiburek, Ph.D., P.Eng, ASHRAE Fellow

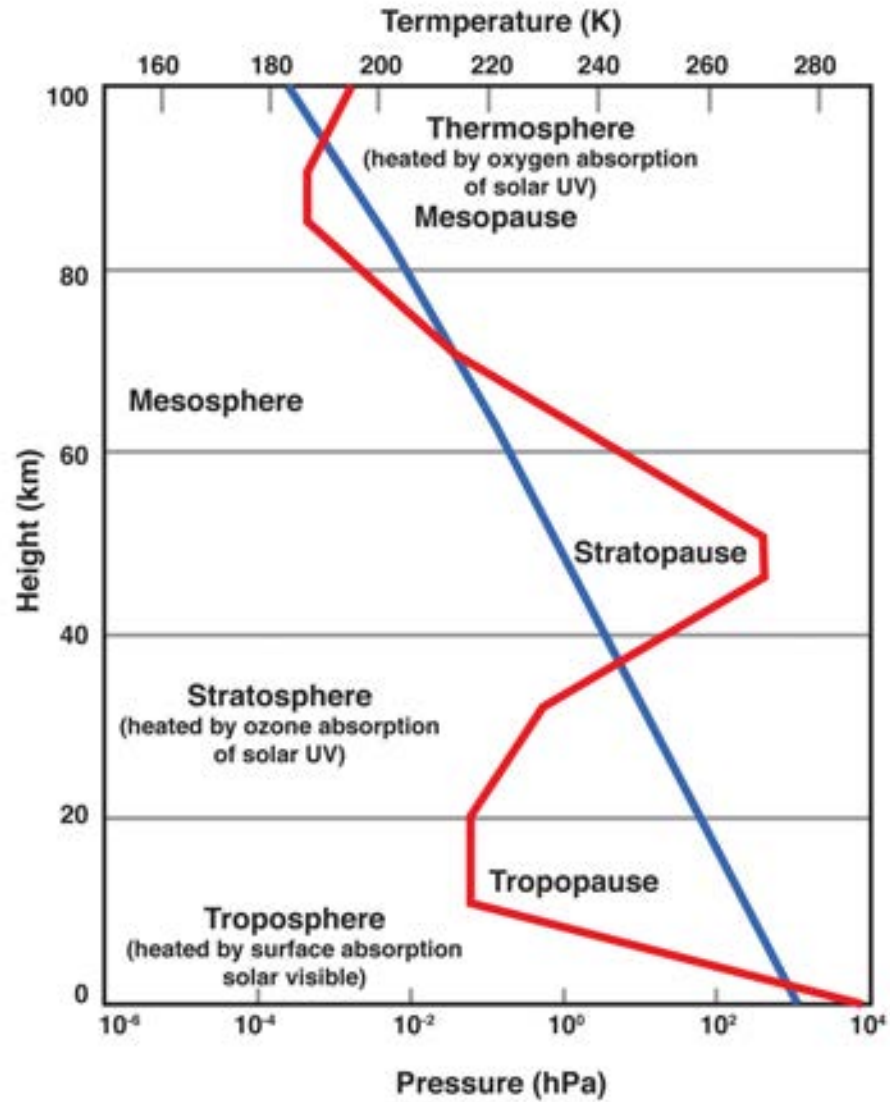
Building Science

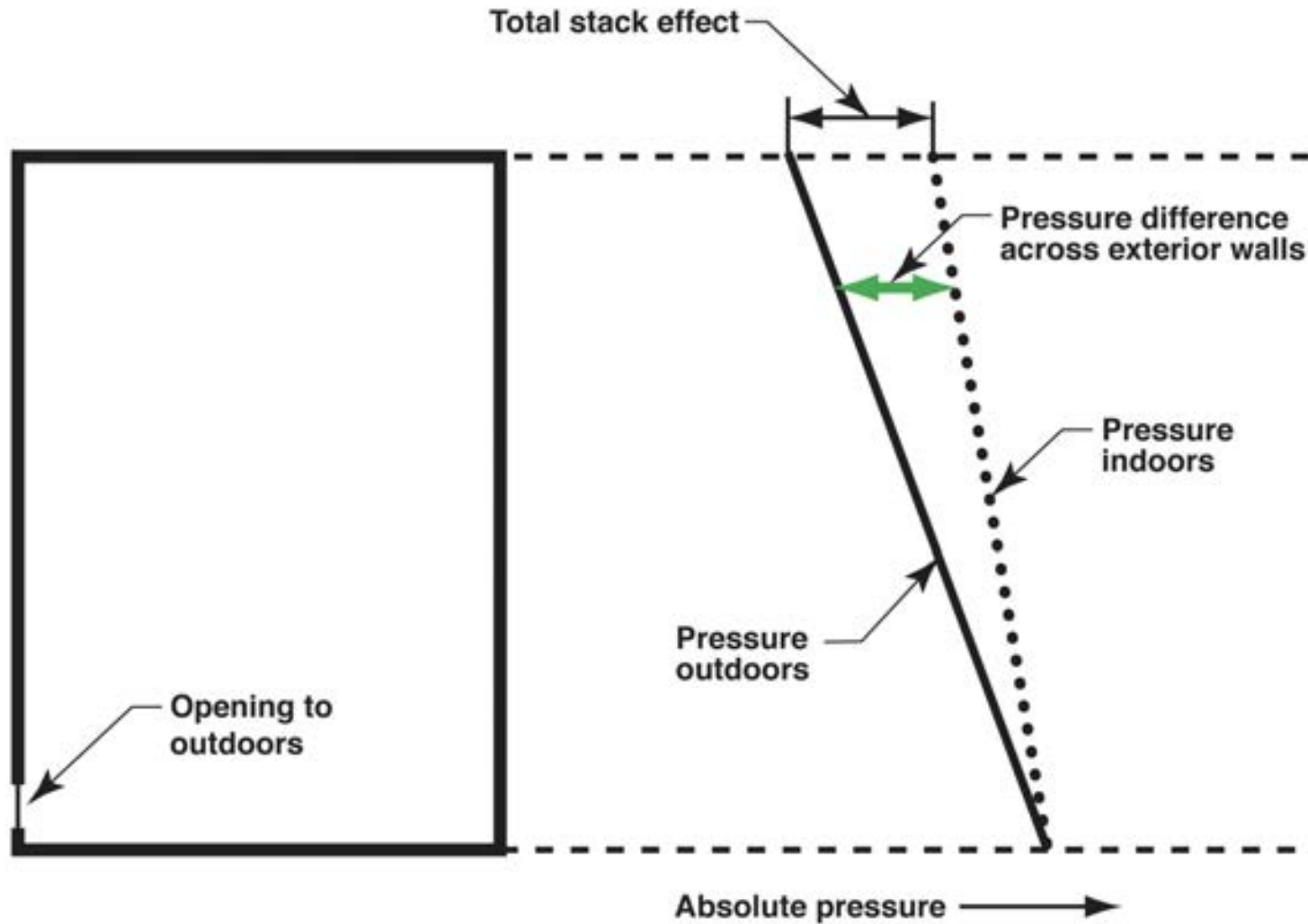
Airflow In Buildings II

presented by www.buildingscience.com

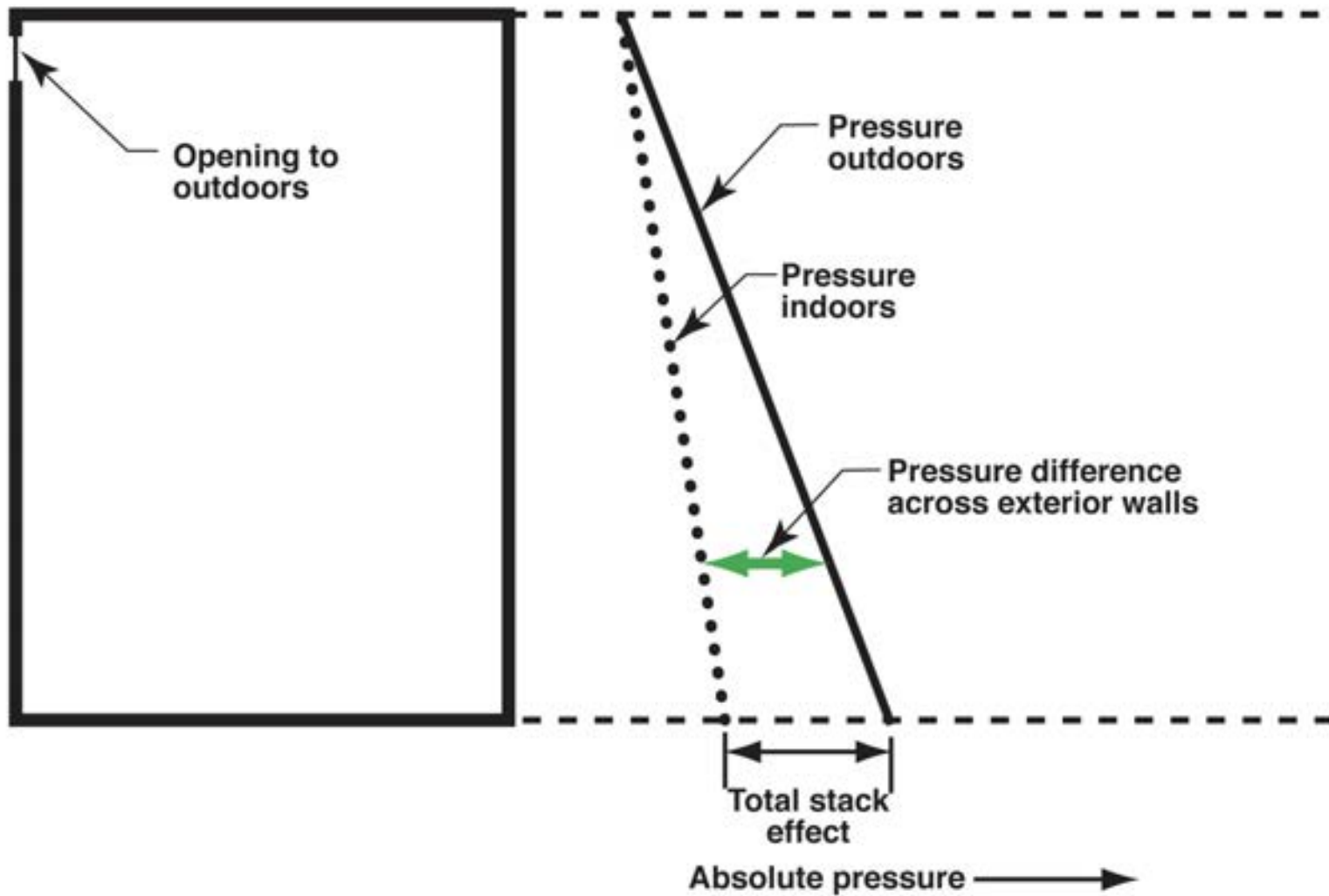
Lapse Rate

U.S. Standard Atmosphere (1976)

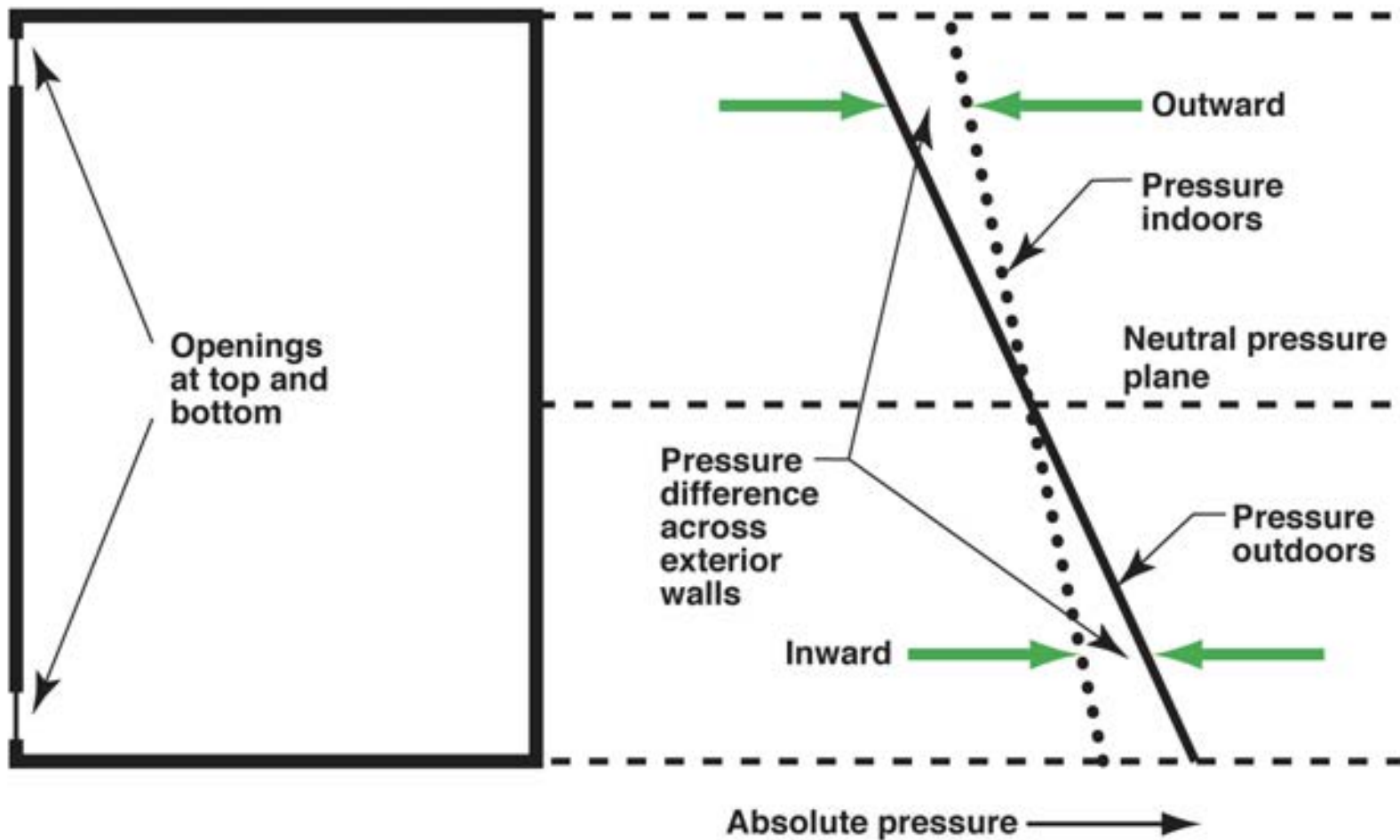




**Figure 11.1: Building with no internal separations with opening at the bottom
(Adapted from G.O. Handegord, 1998)**



**Figure 11.2: Building with no internal separations with opening at the top
(Adapted from G.O. Handegord, 1998)**



**Figure 11.3: Building with no internal separations with openings at top and bottom
(Adapted from G.O. Handegord, 1998)**

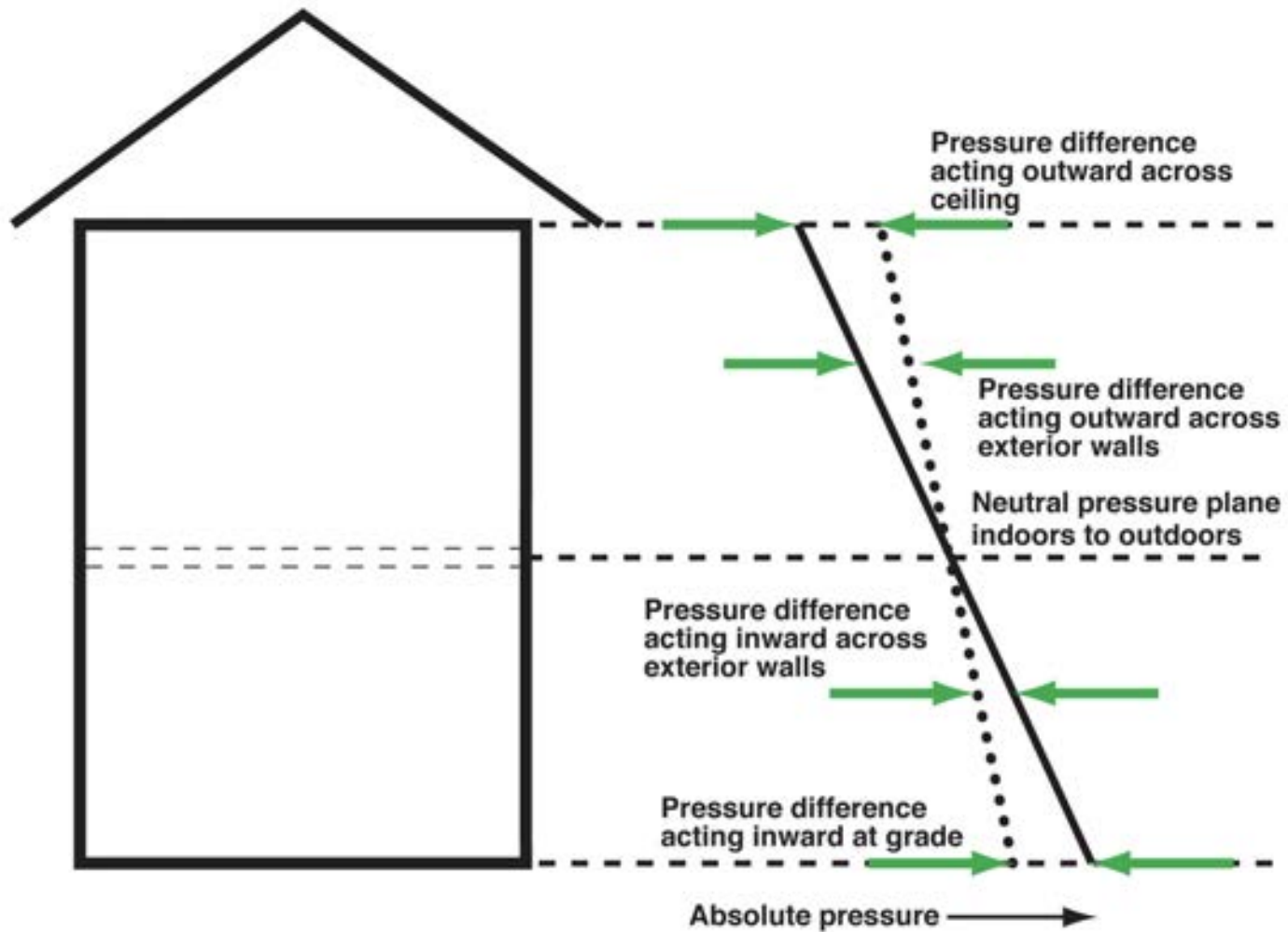
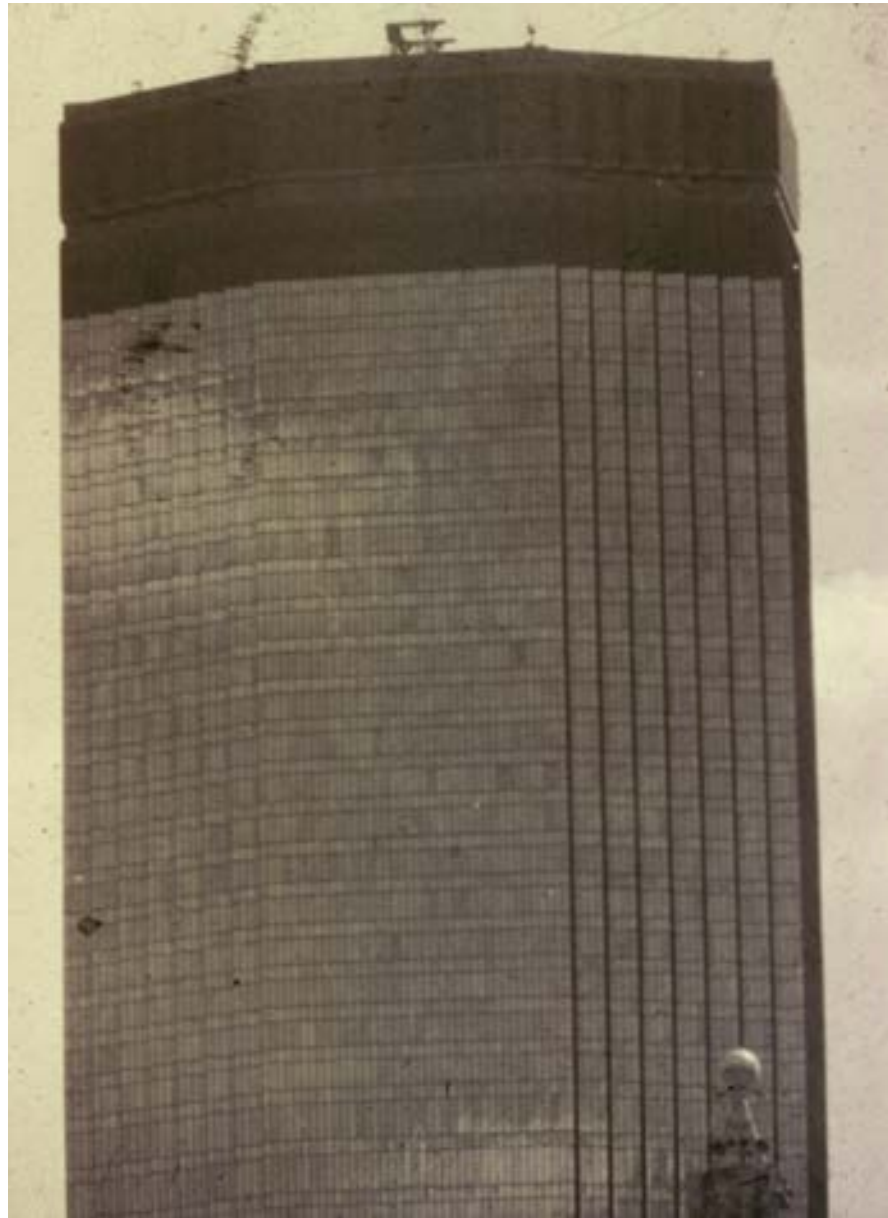
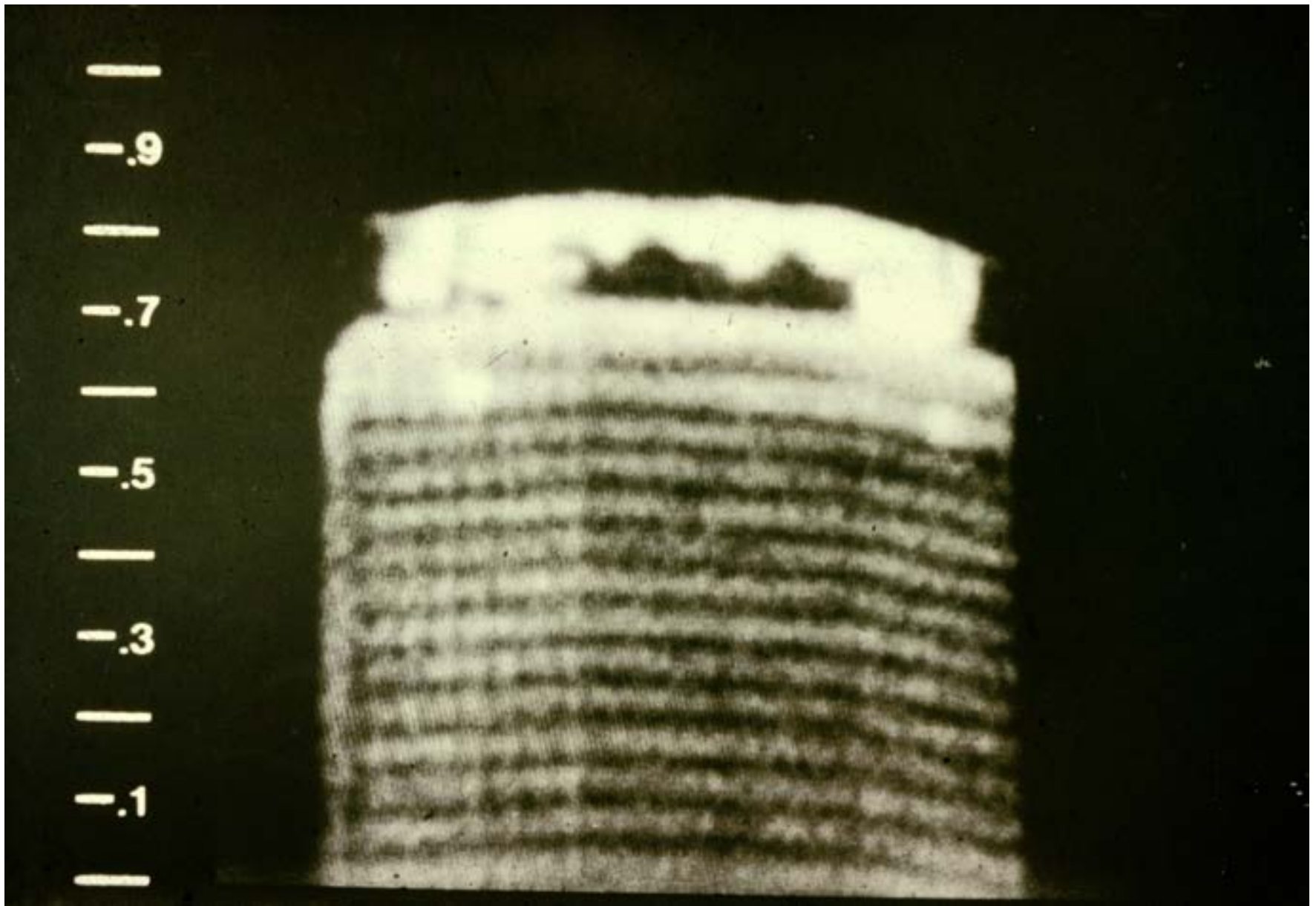


Figure 11.4: Basic two storey house with vented attic
(Adapted from G.O. Handegord, 1998)



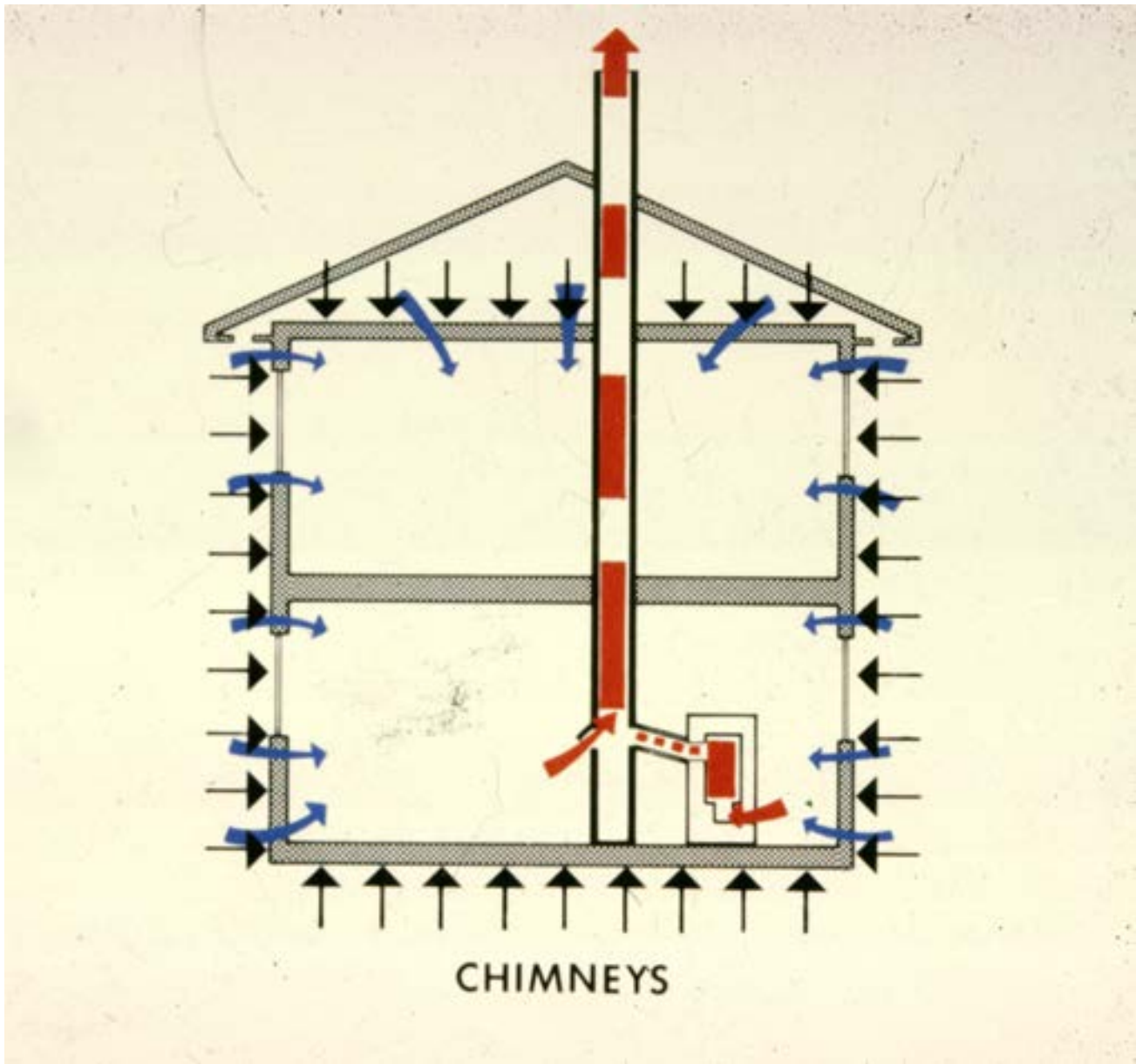


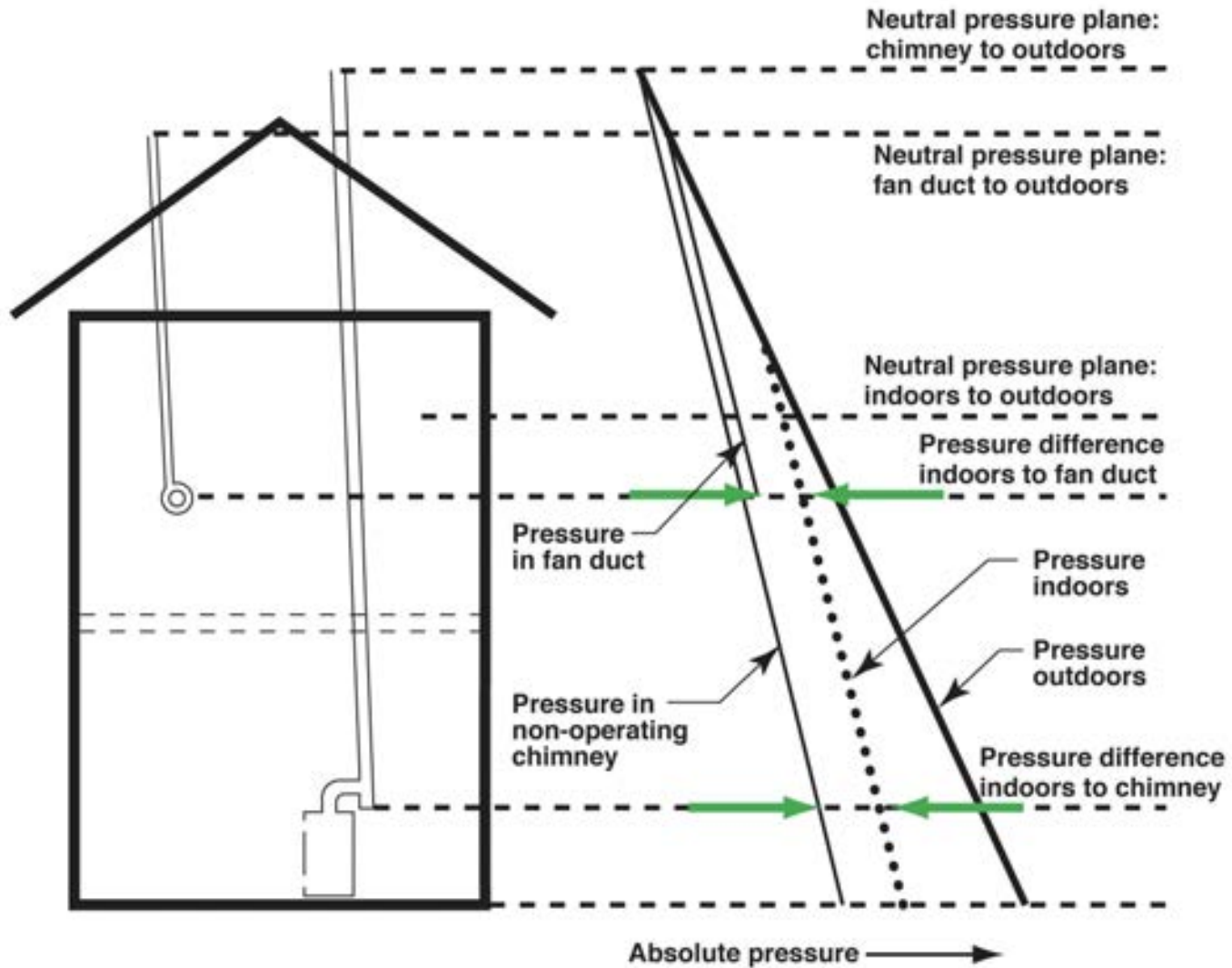












**Figure 11.5: Two storey house with non-operating chimney and exhaust fan
(Adapted from G.O. Handegord, 1998)**

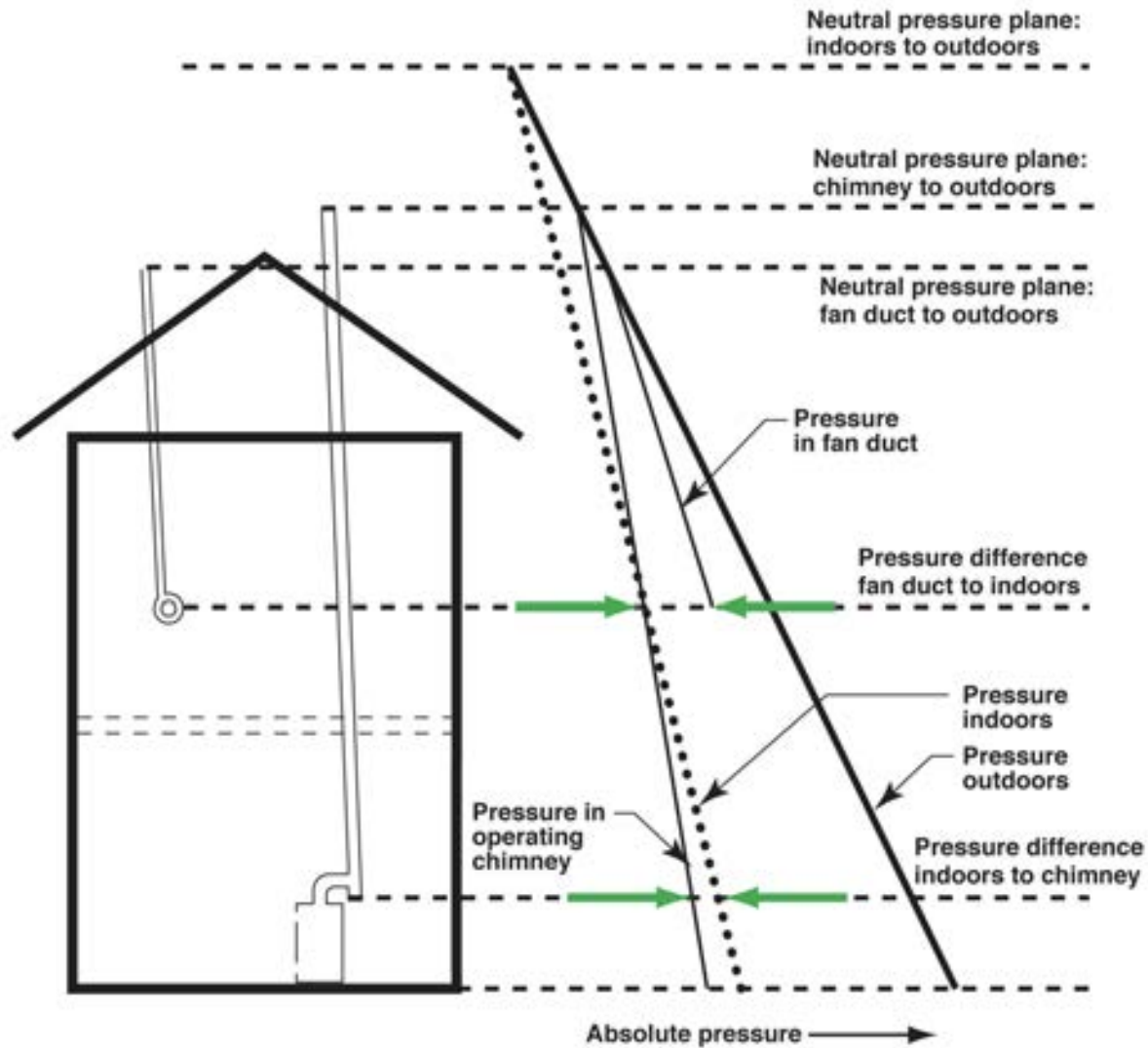
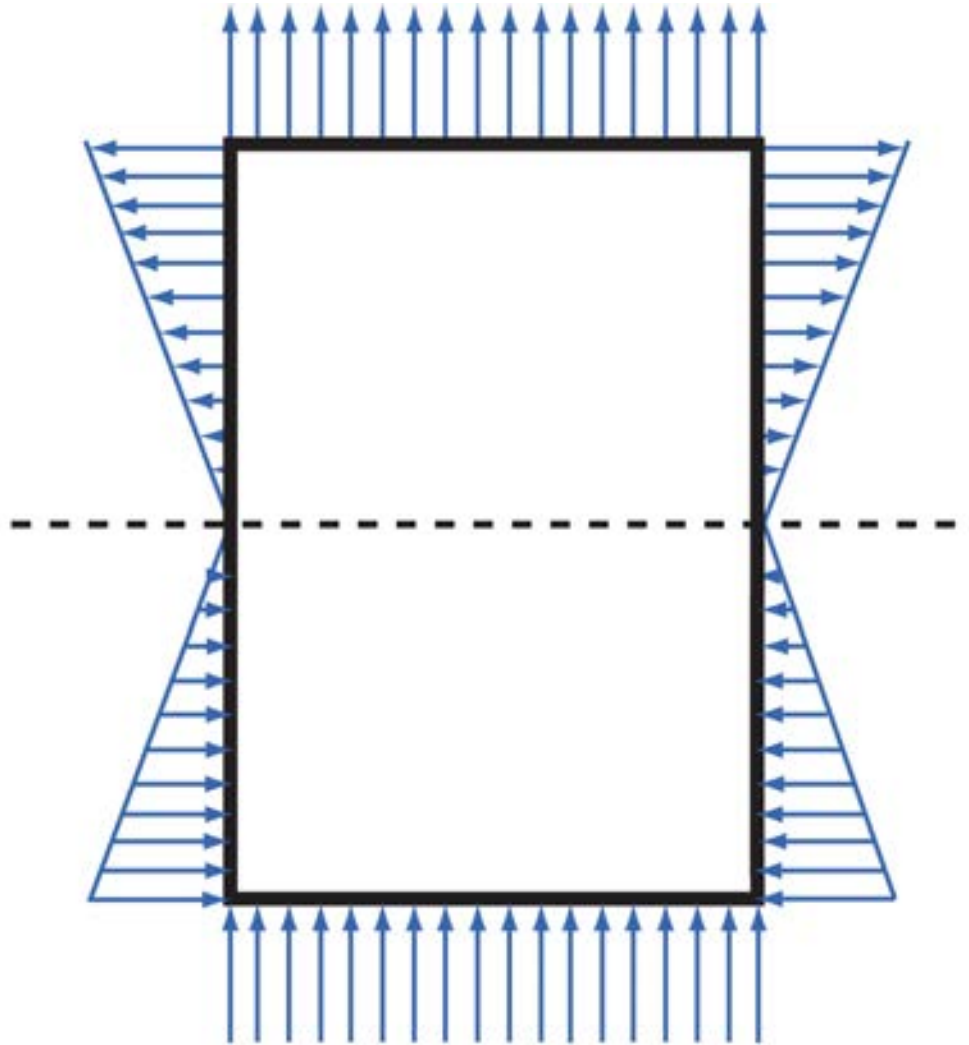
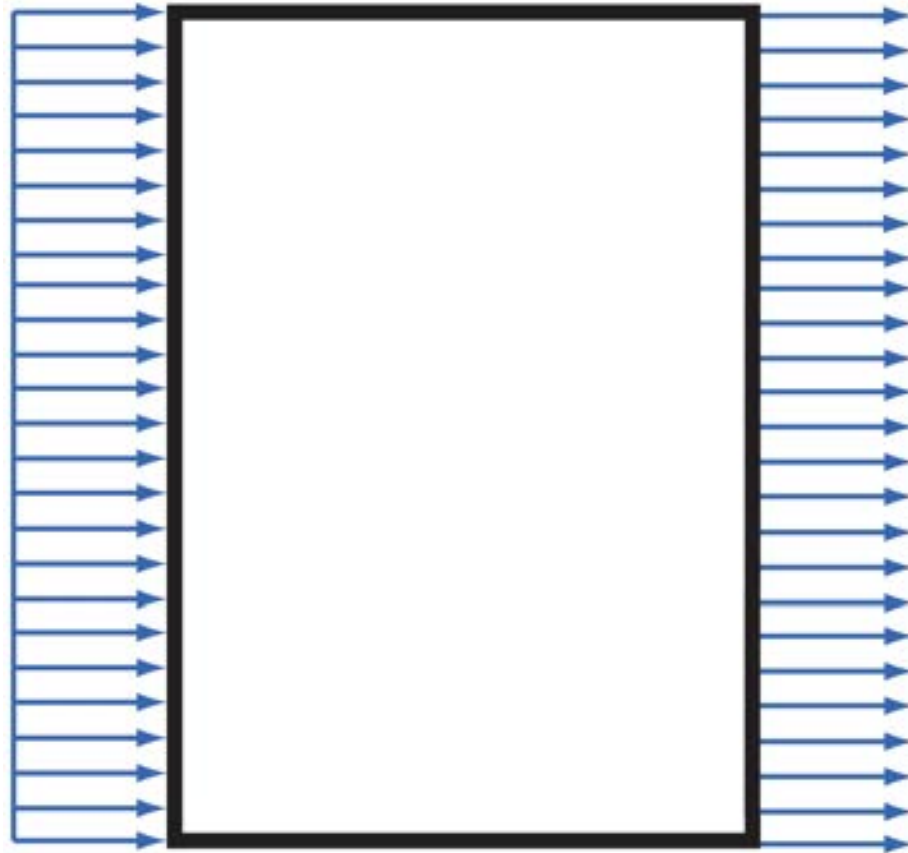


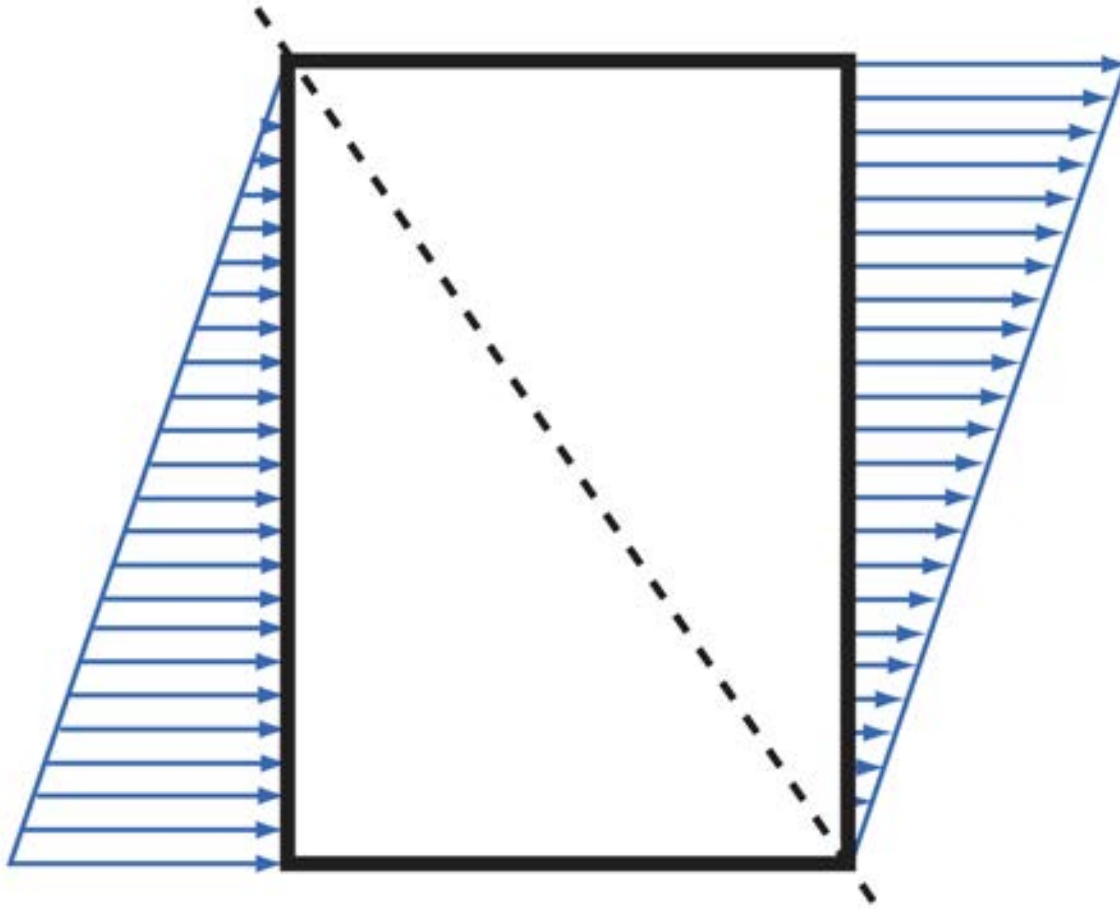
Figure 11.6: Two storey house with operating chimney
(Adapted from G.O. Handegord, 1998)



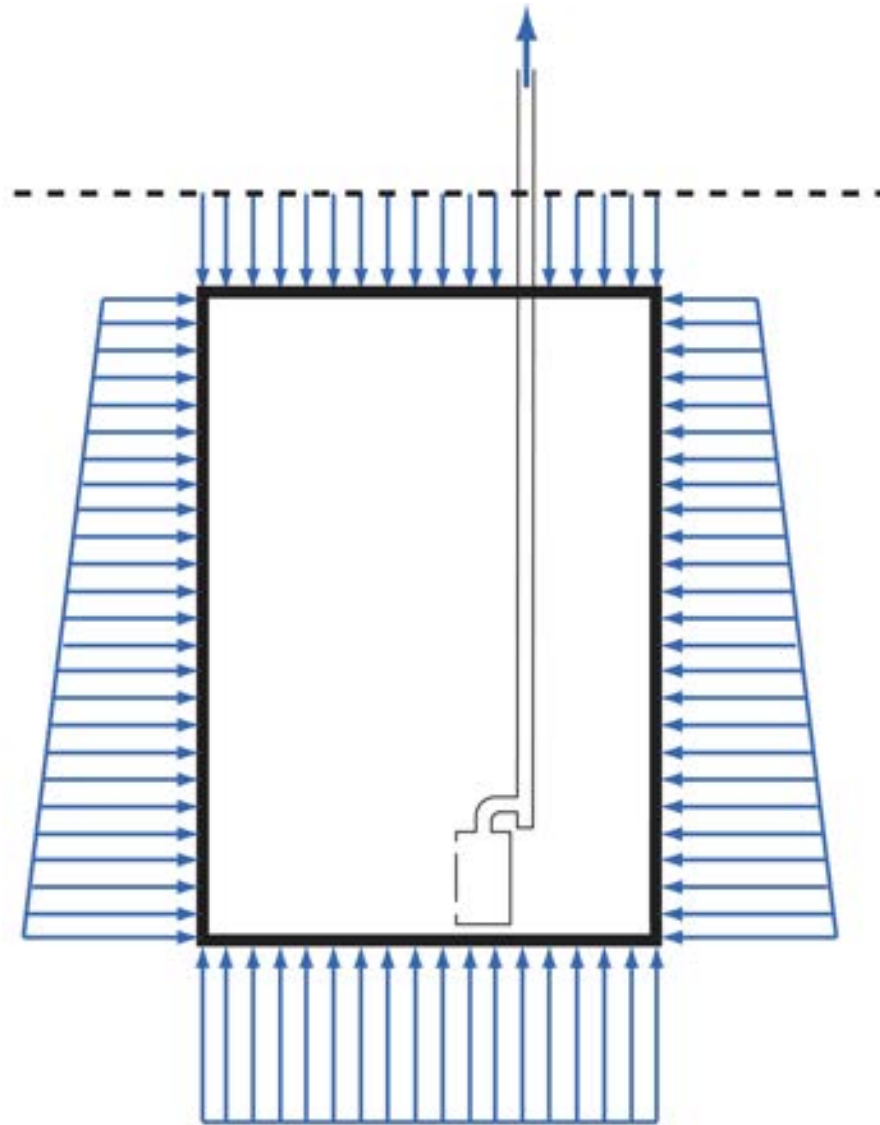
Stack effect



Wind

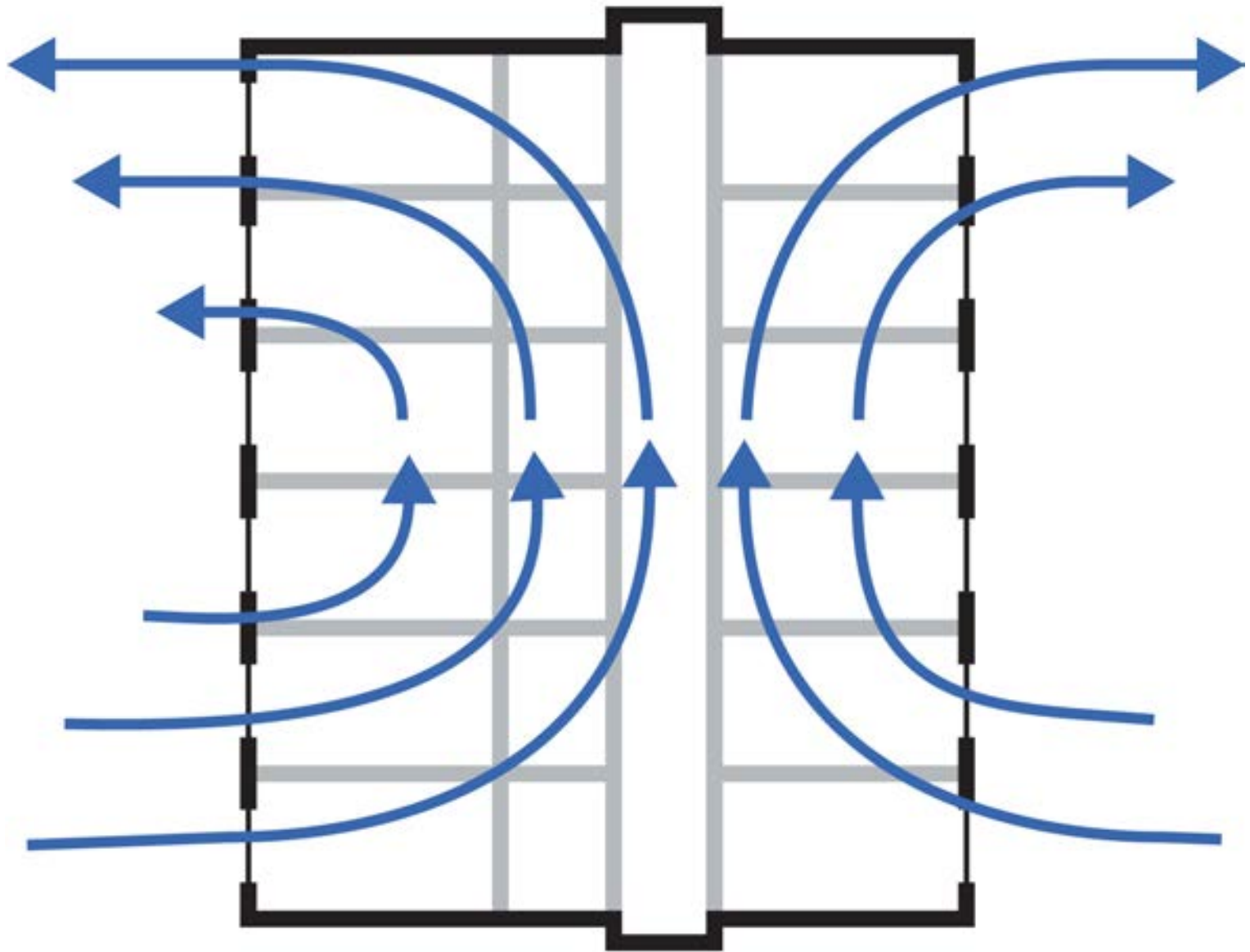


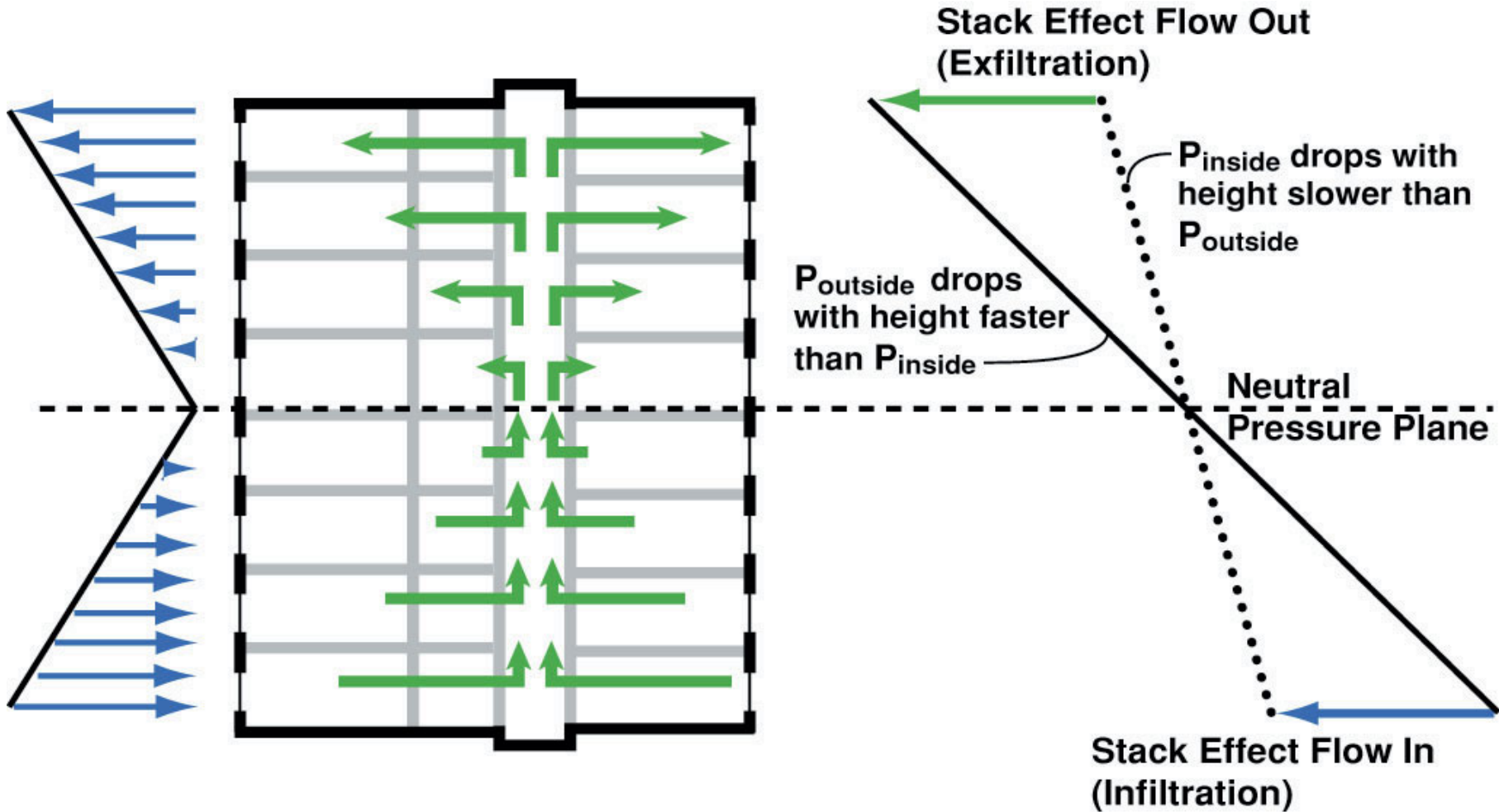
Stack effect and wind

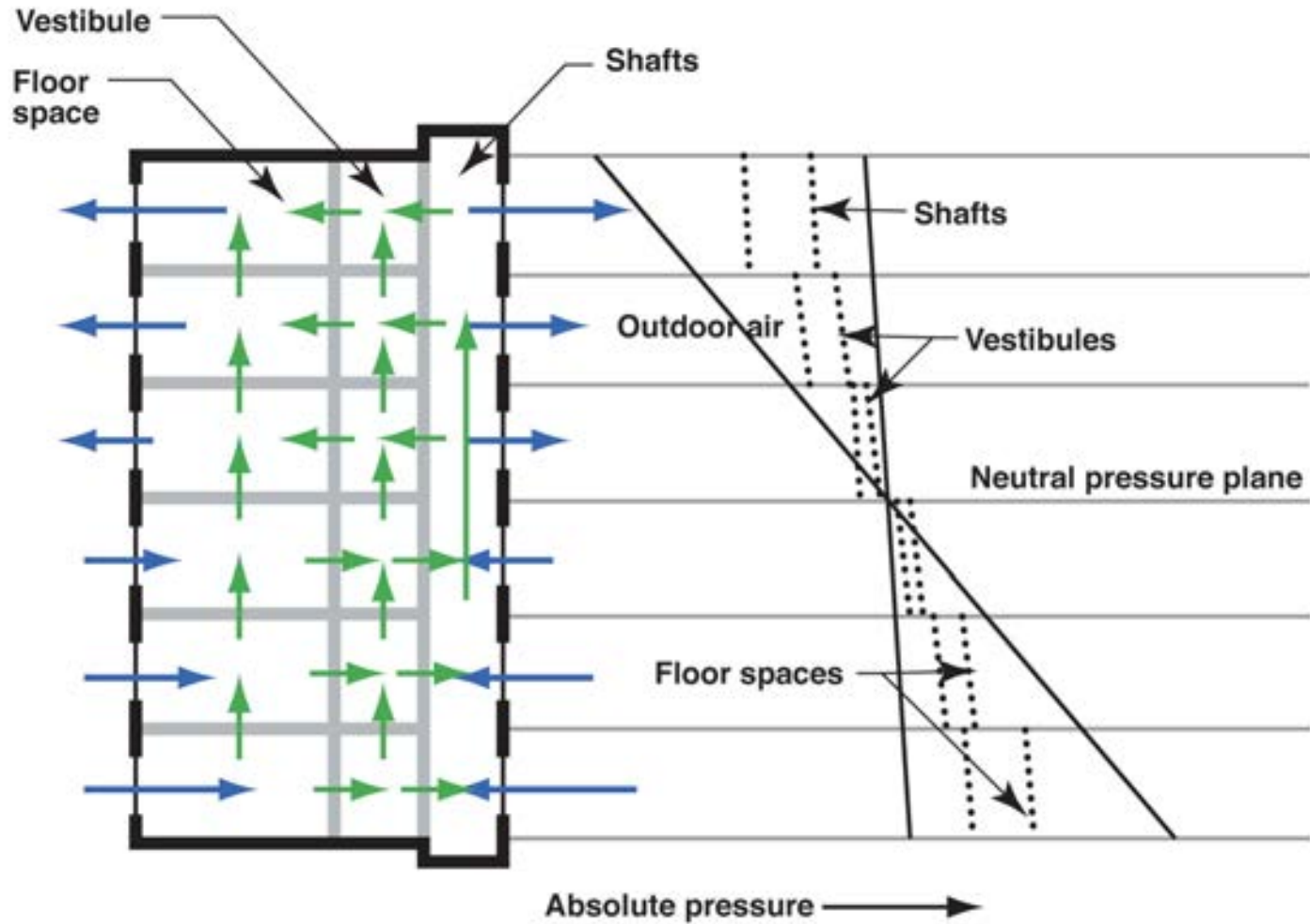


Chimney effect

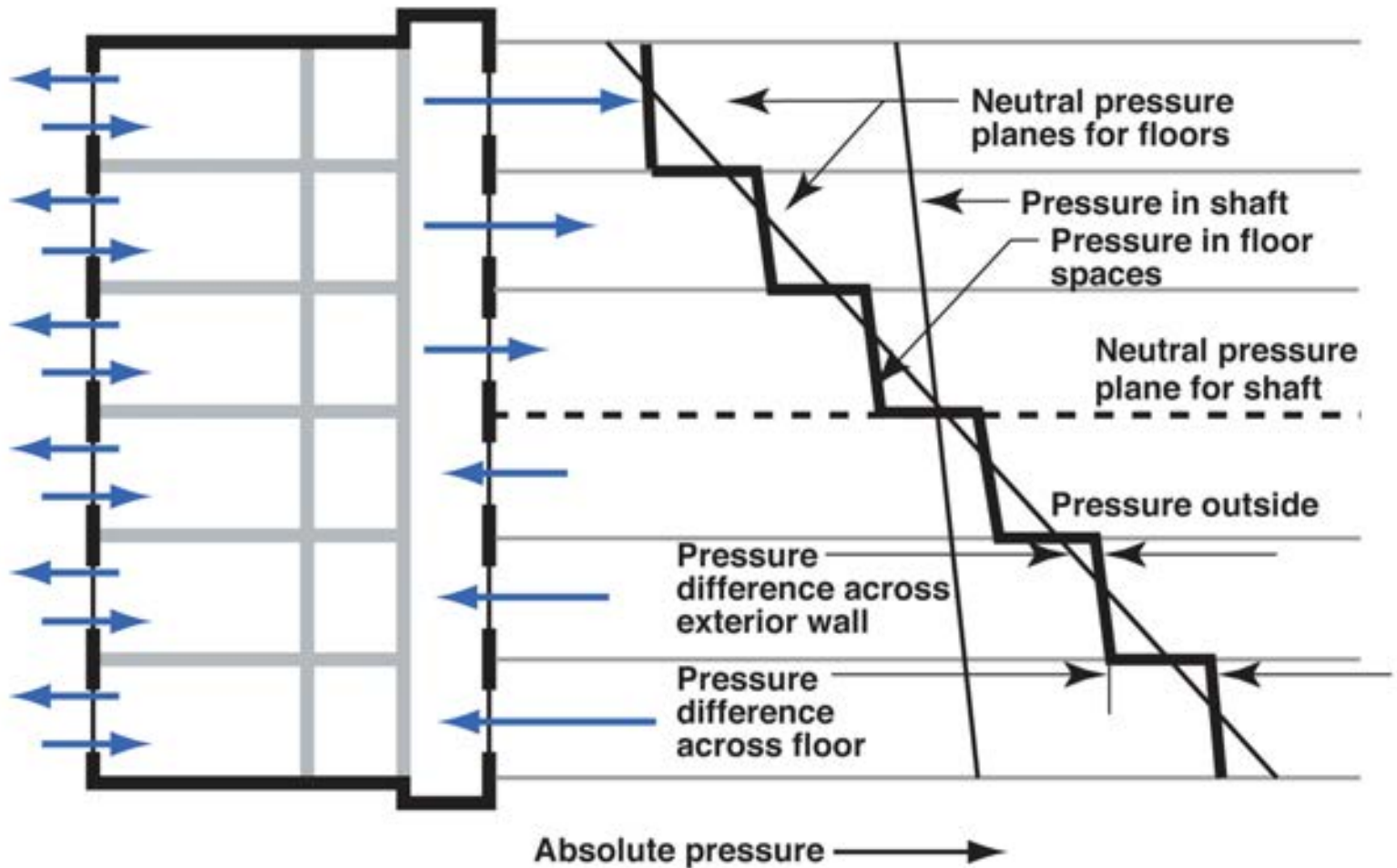




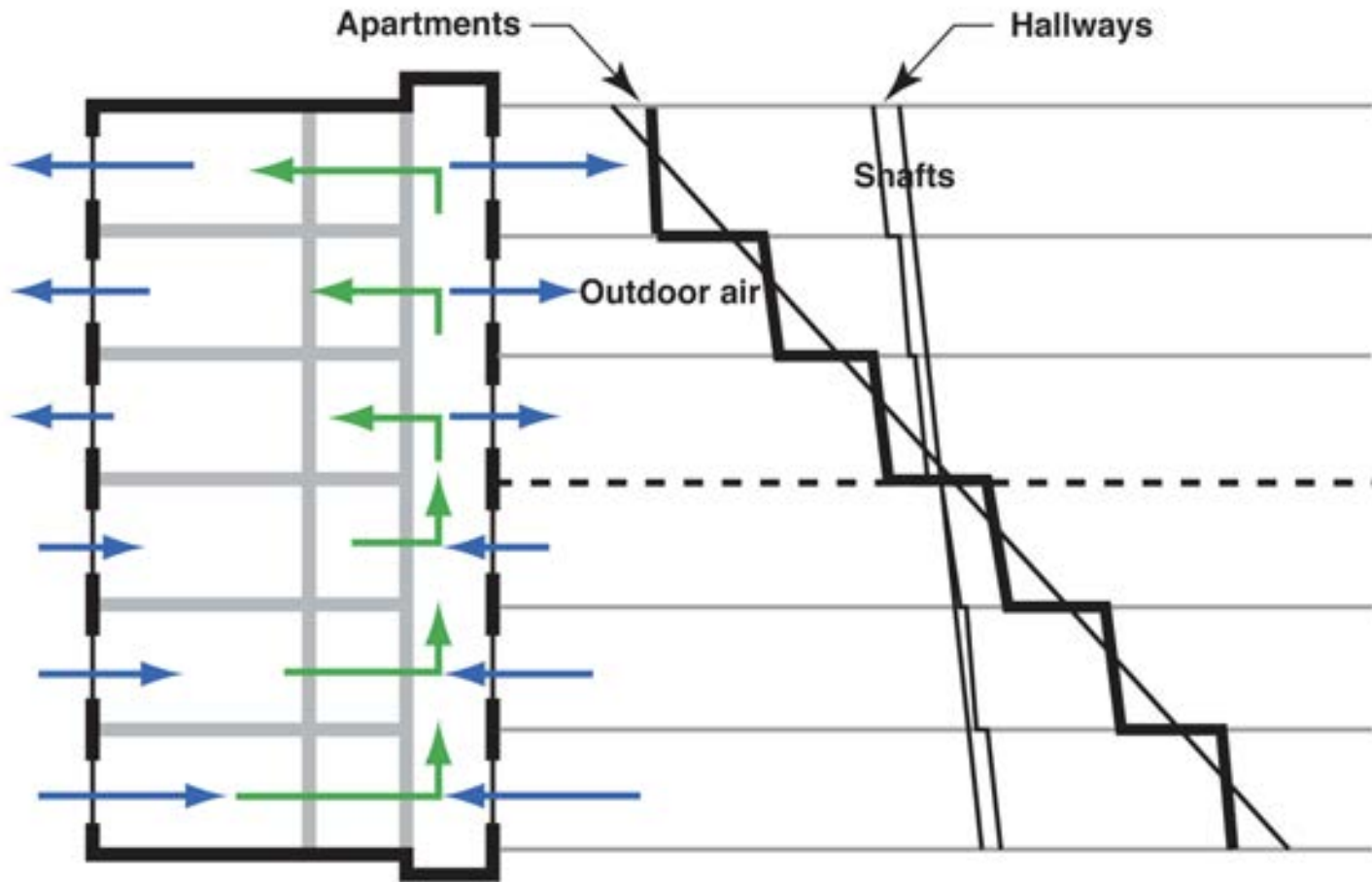




**Figure 11.8: Stack effect pressures in high rise office building
(Adapted from G.O. Handegord, 1998)**

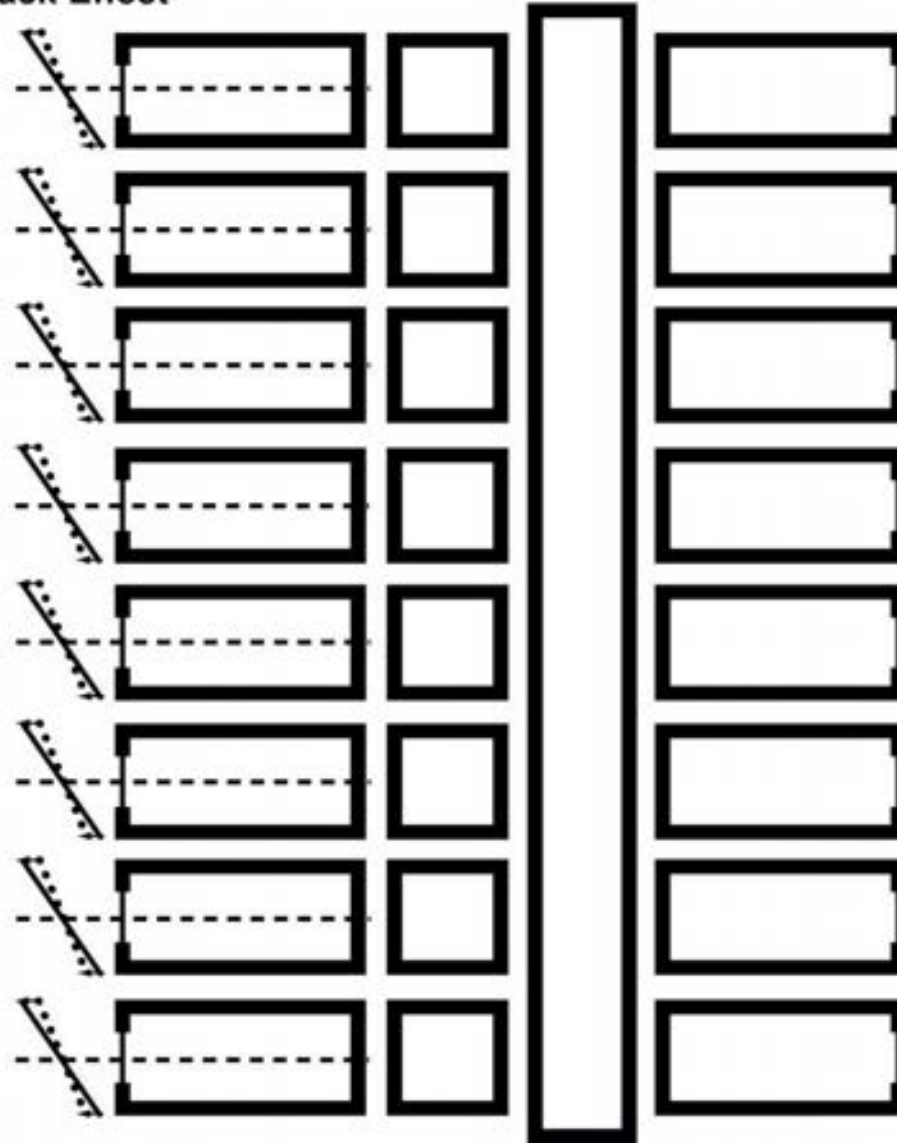


**Figure 11.9: Multi-storey building with floor spaces isolated from vertical shafts
(Adapted from G.O. Handegord, 1998)**



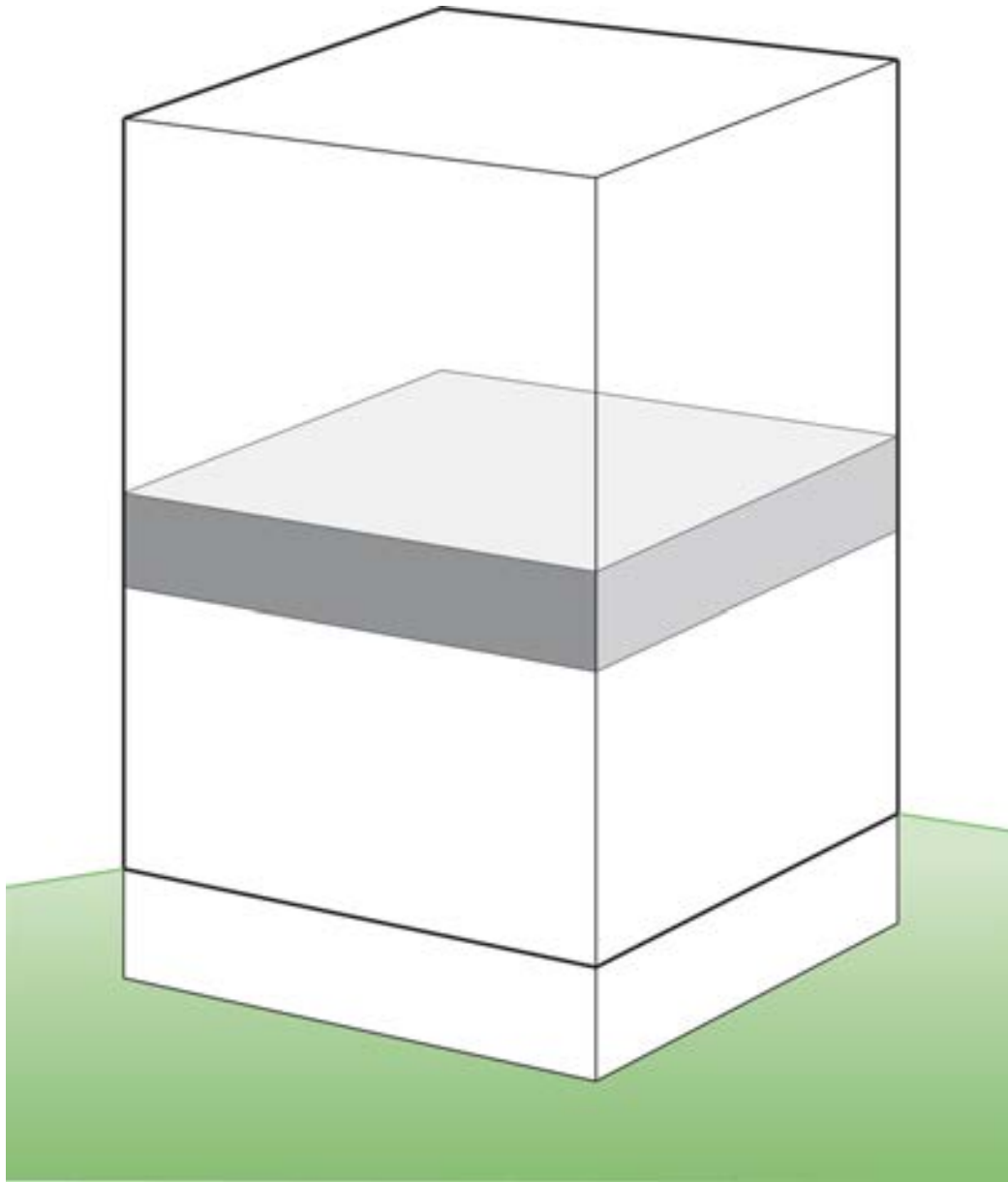
**Figure 11.12: Apartment building with tighter apartment entry doors
(Adapted from G.O. Handegord, 1998)**

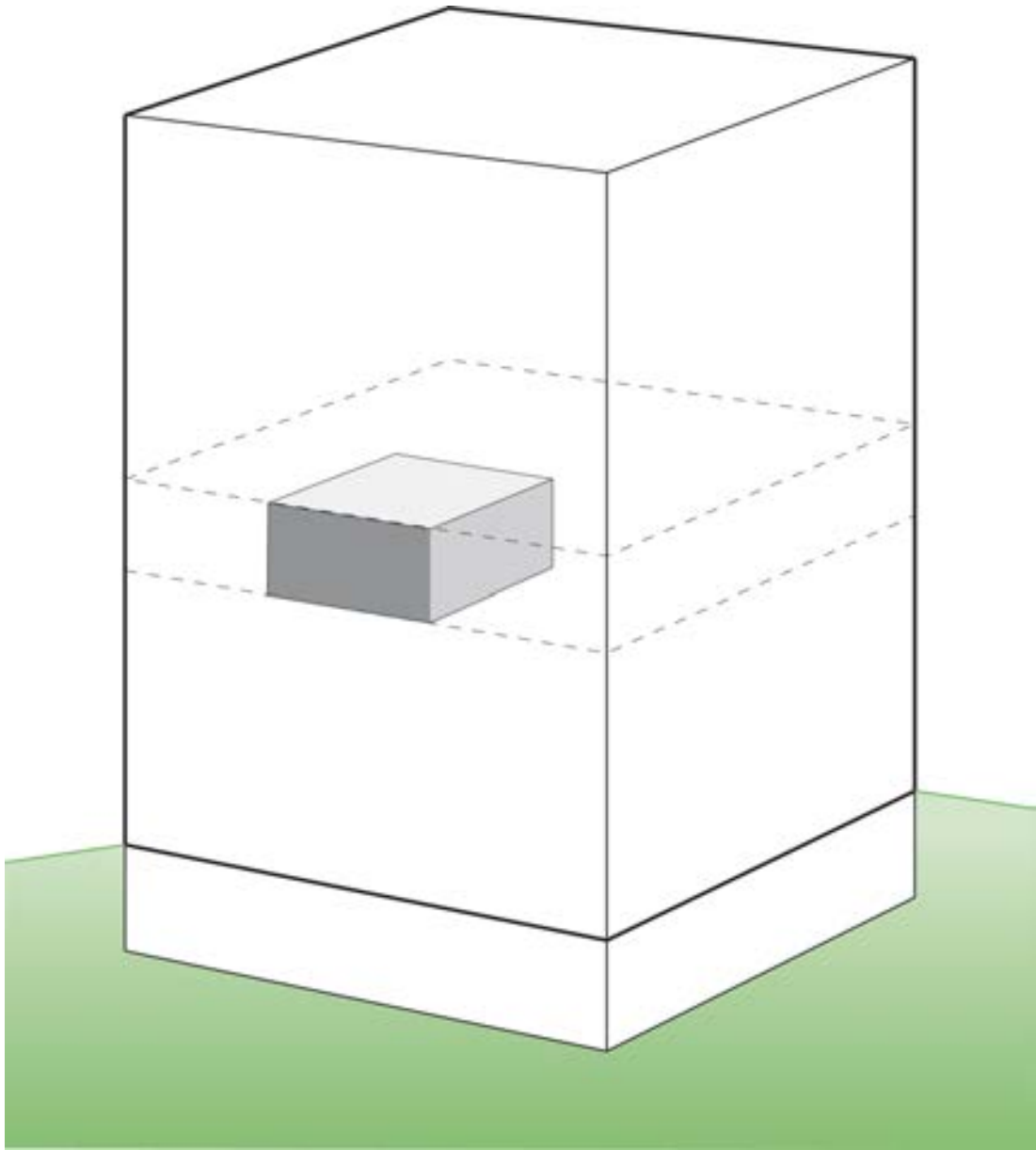
Reduced Individual
Unit Stack Effect

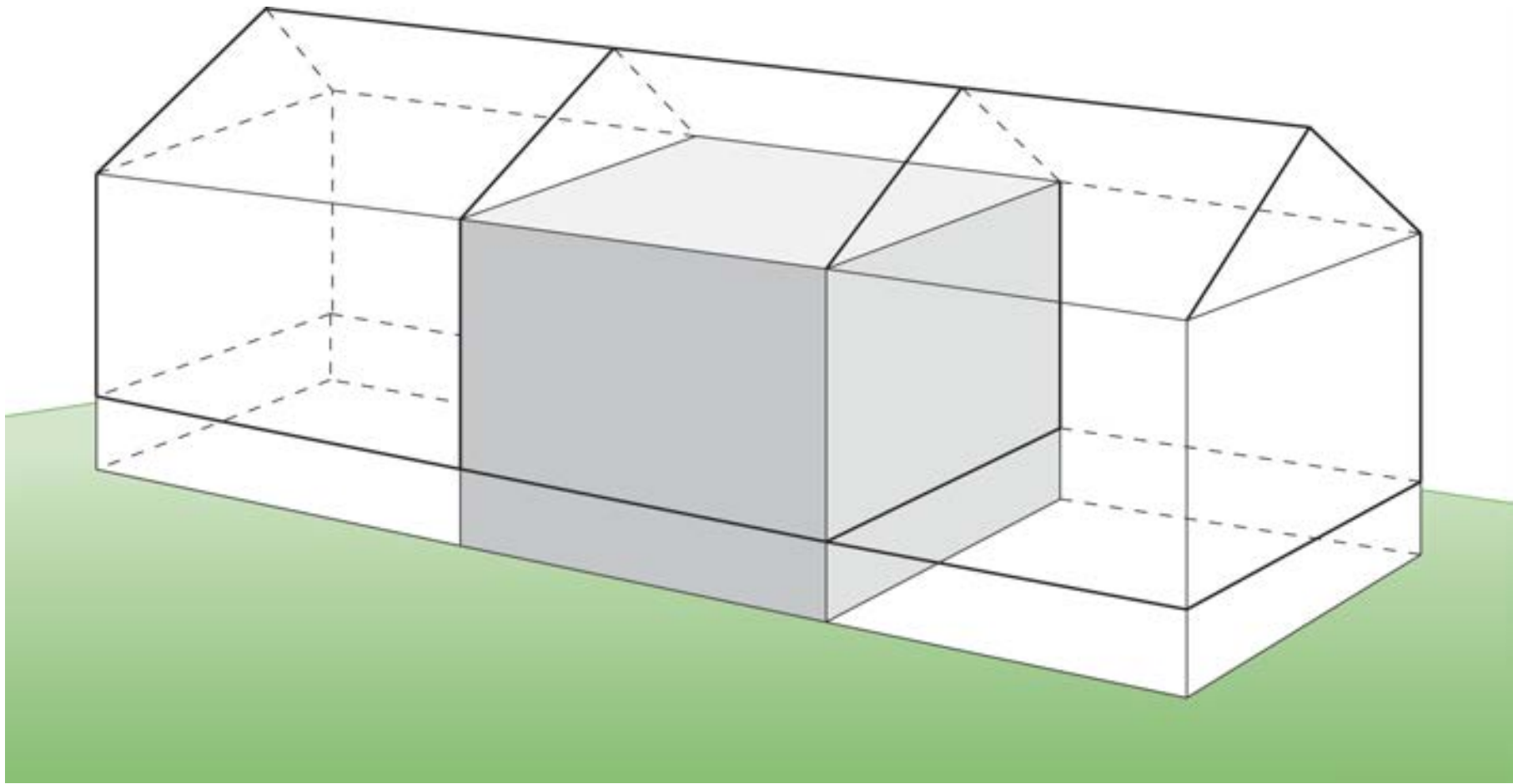








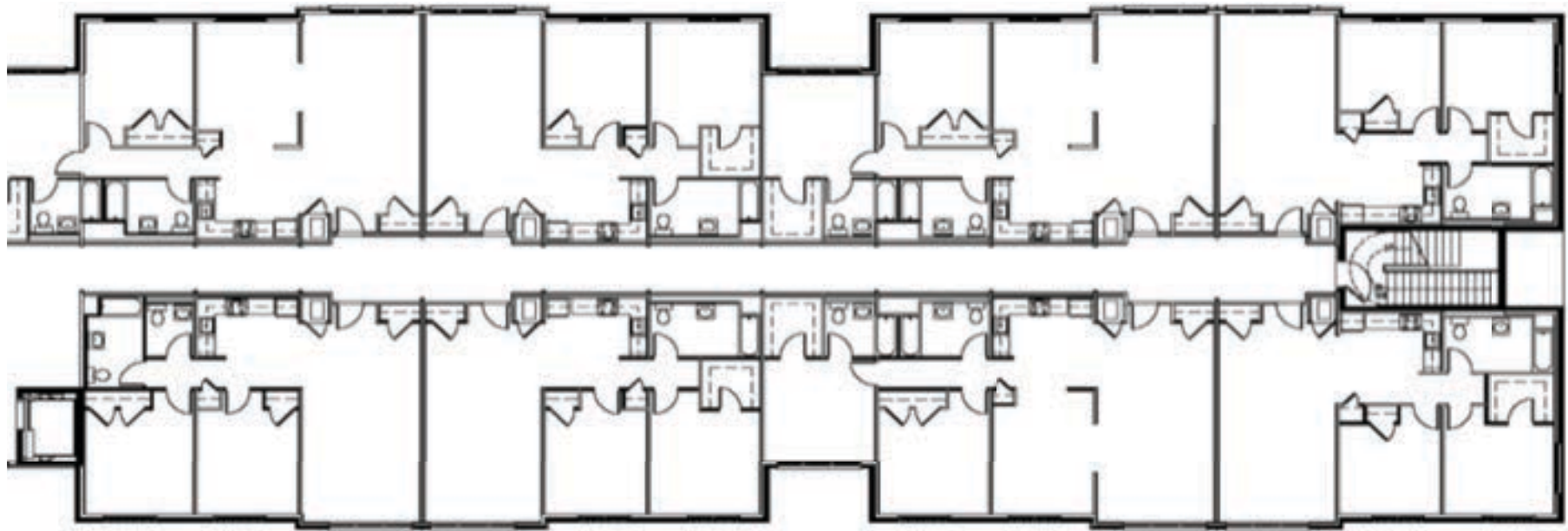




Air Barrier Metrics

Material	0.02 l/(s-m ²)@75 Pa
Assembly	0.20 l/(s-m ²)@75 Pa
Enclosure	2.00 l/(s-m ²)@75 Pa







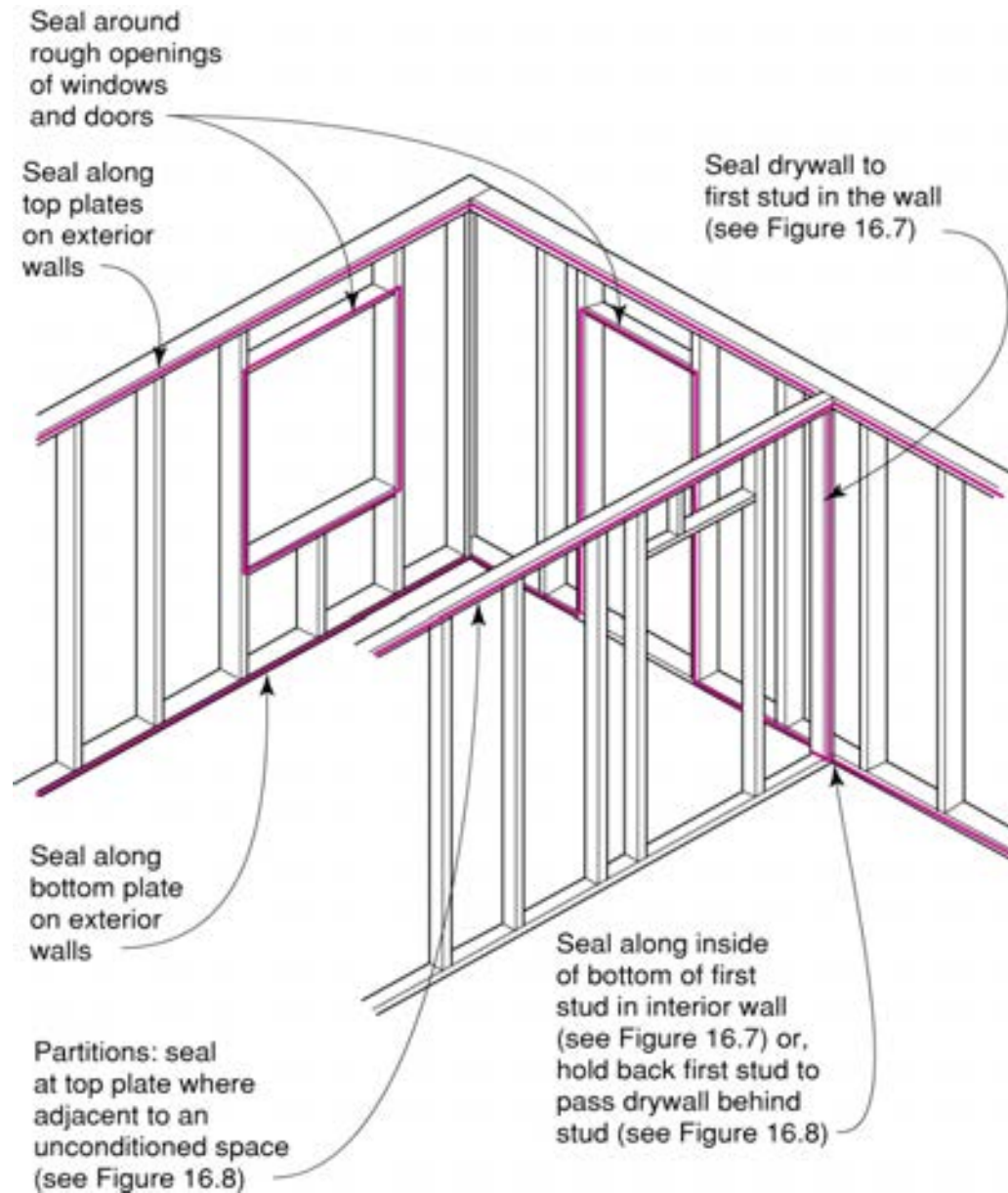


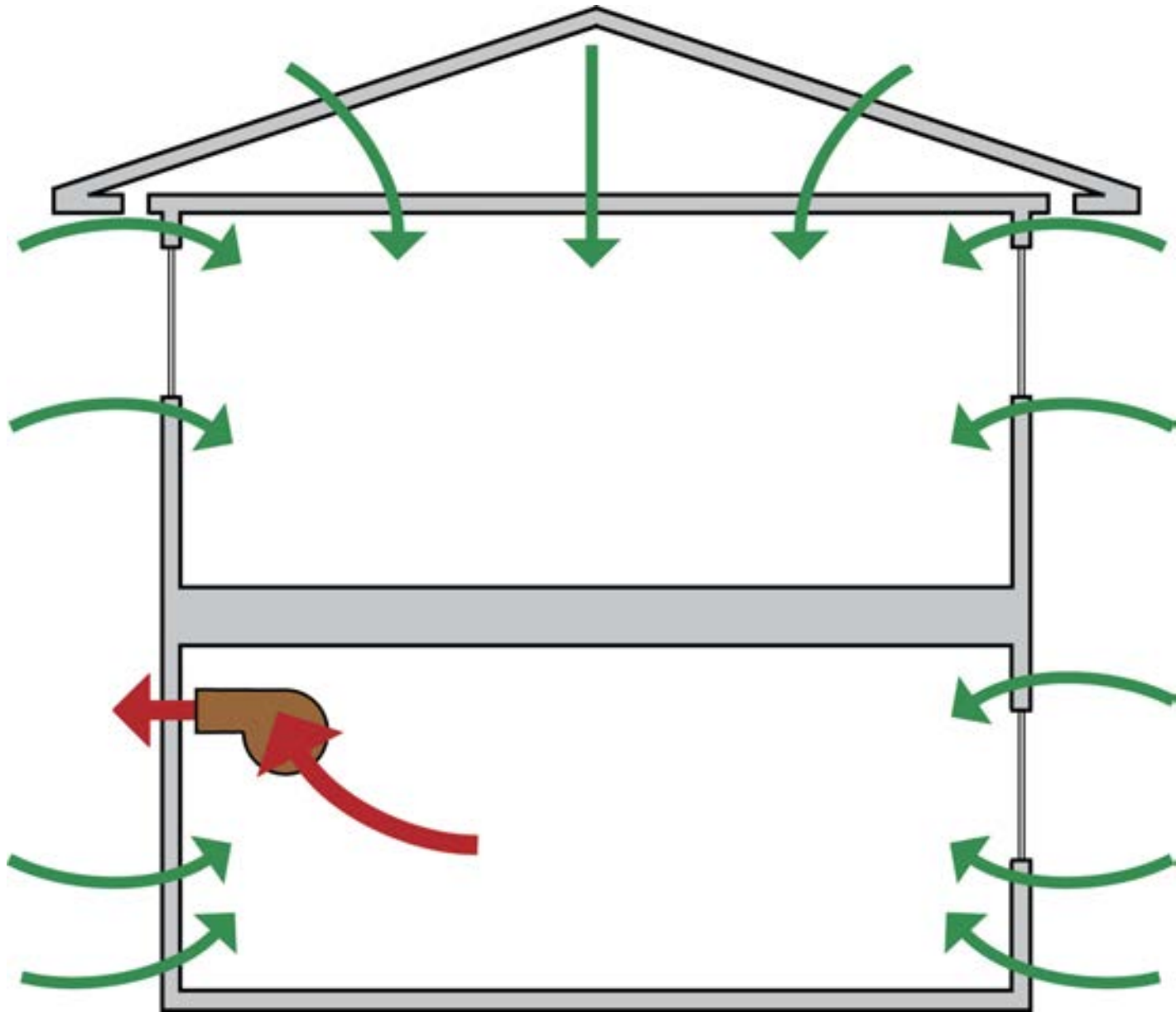






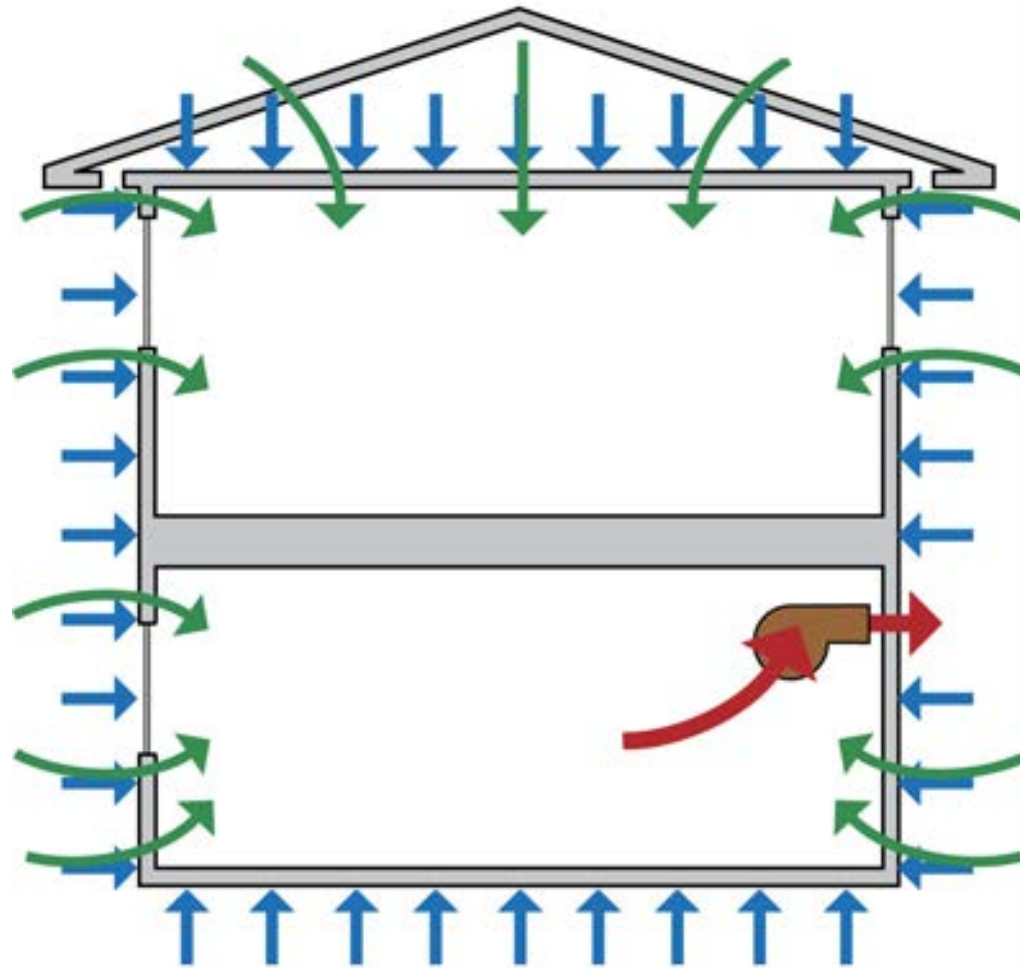






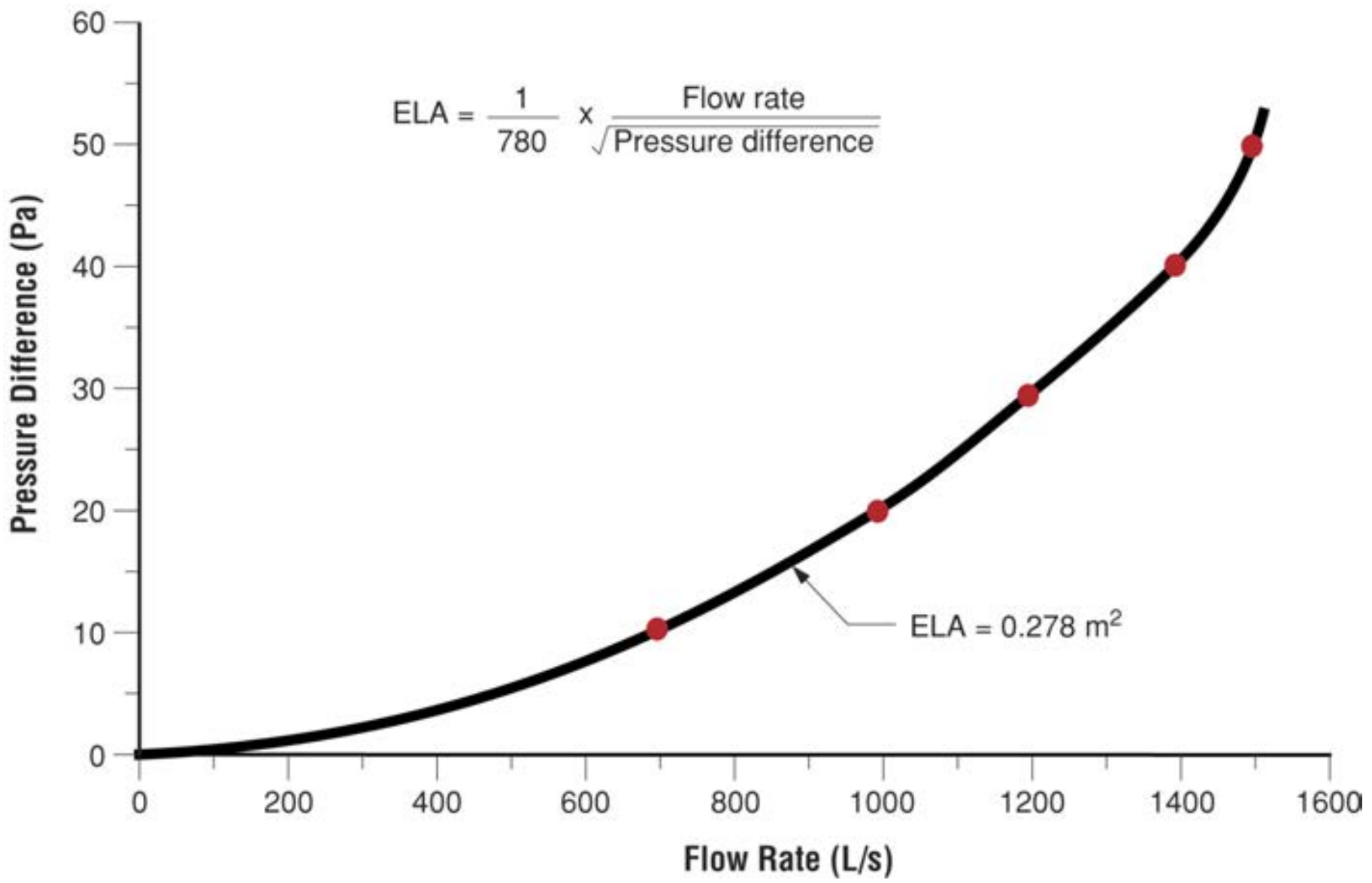


$$ELA = C \times \frac{\text{Rate of flow}}{\sqrt{\text{Pressure difference}}}$$

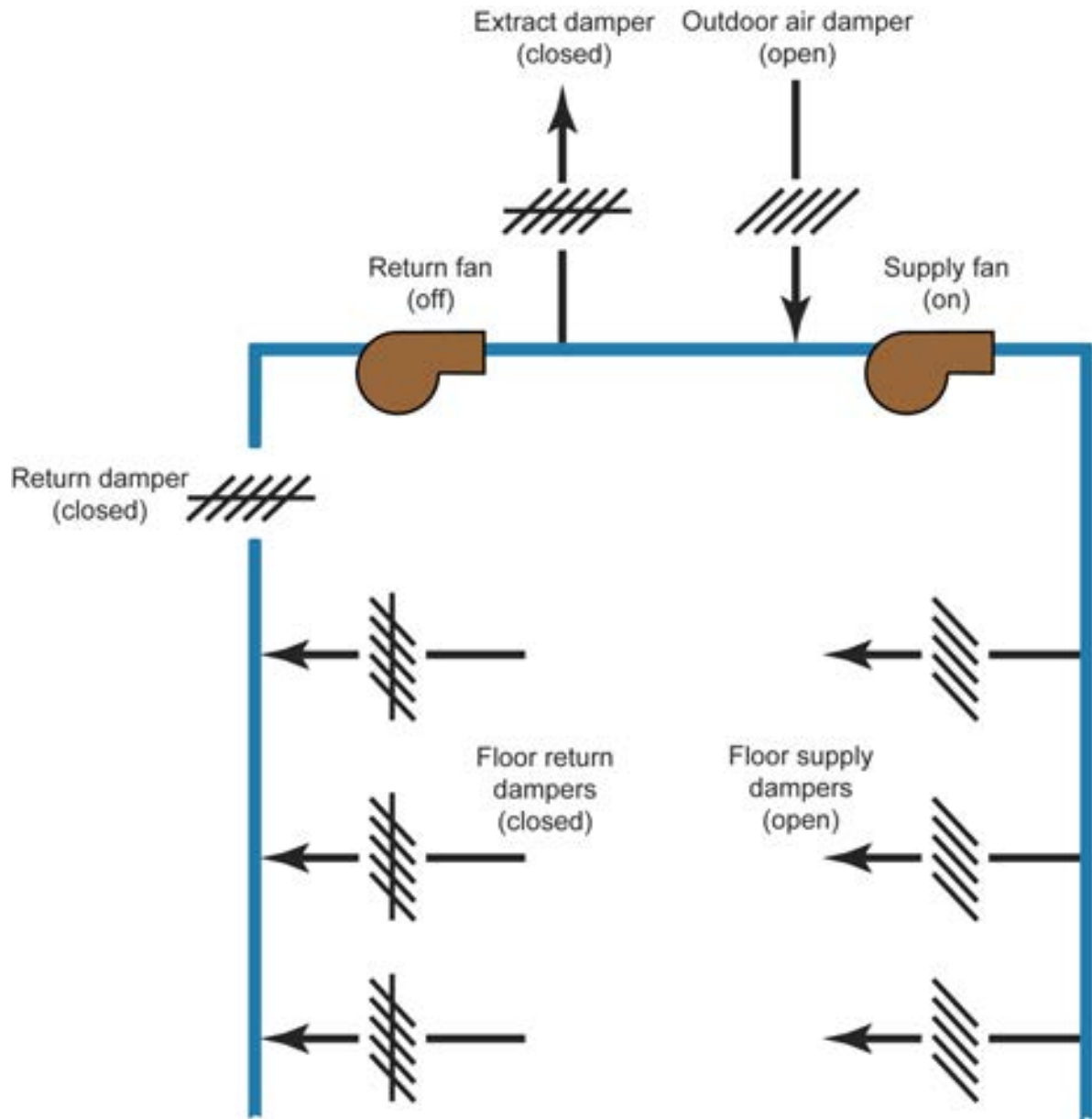


$$(\text{Meters})^2 = \frac{1}{780} \times \frac{\text{Litres per second}}{\sqrt{\text{Pascals}}}$$

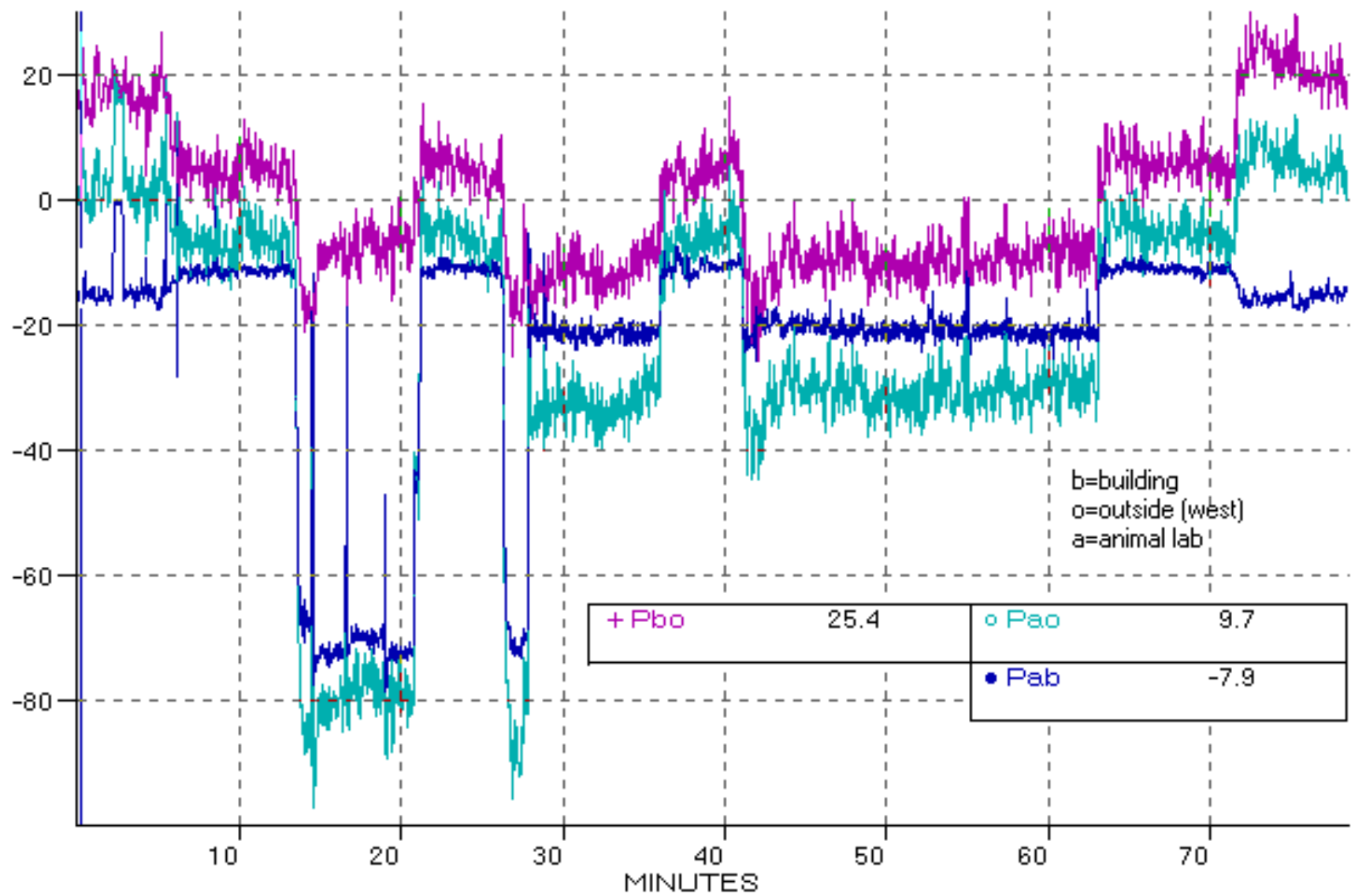
$$ELA = \frac{1}{780} \times \frac{\text{Flow rate}}{\sqrt{\text{Pressure difference}}}$$

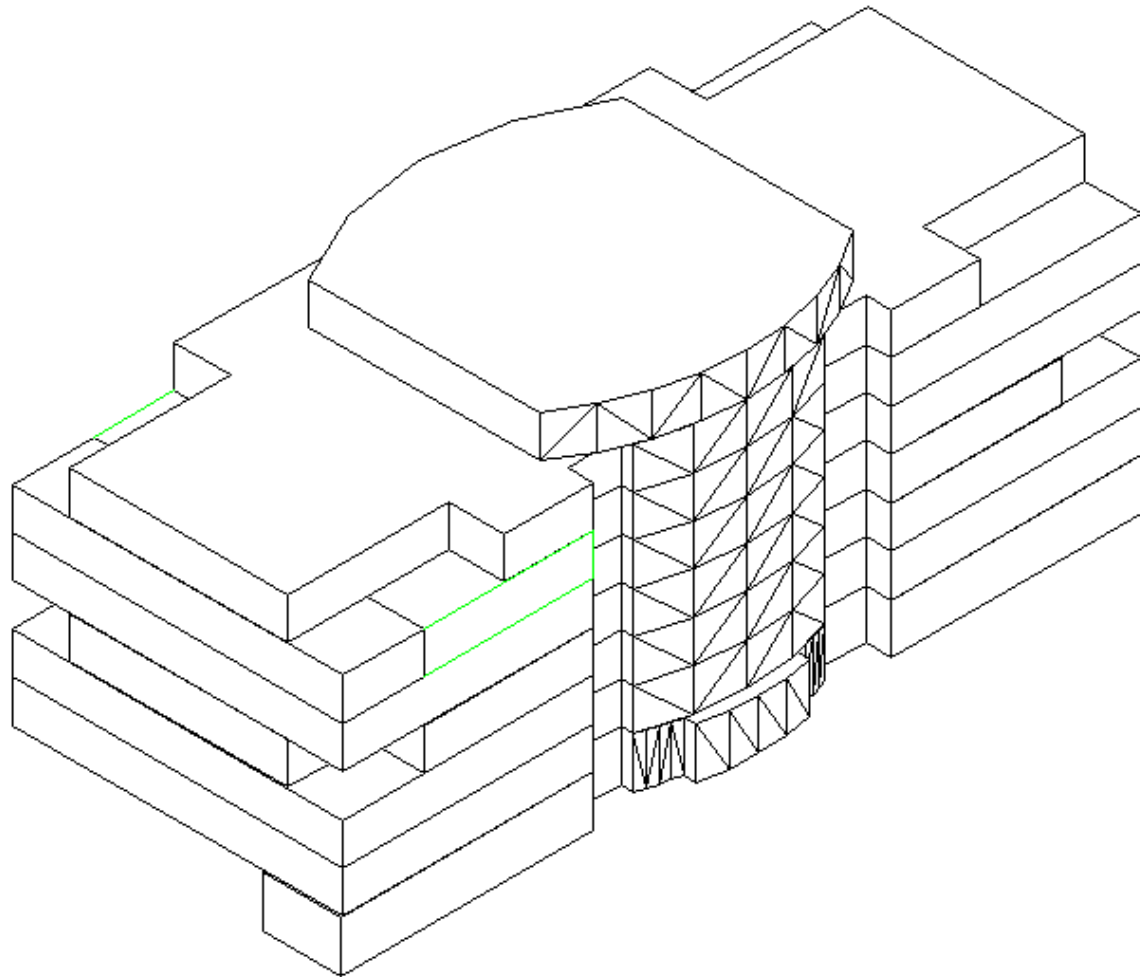












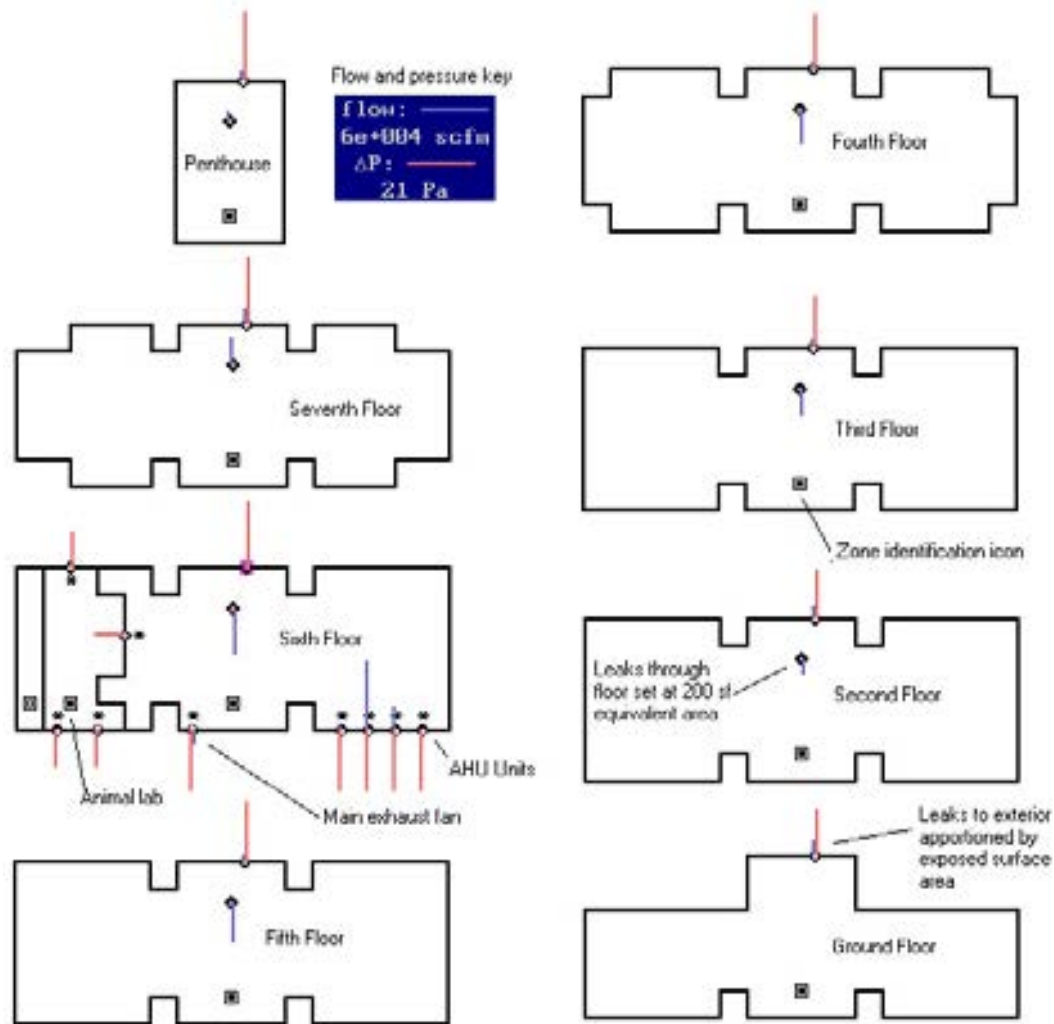






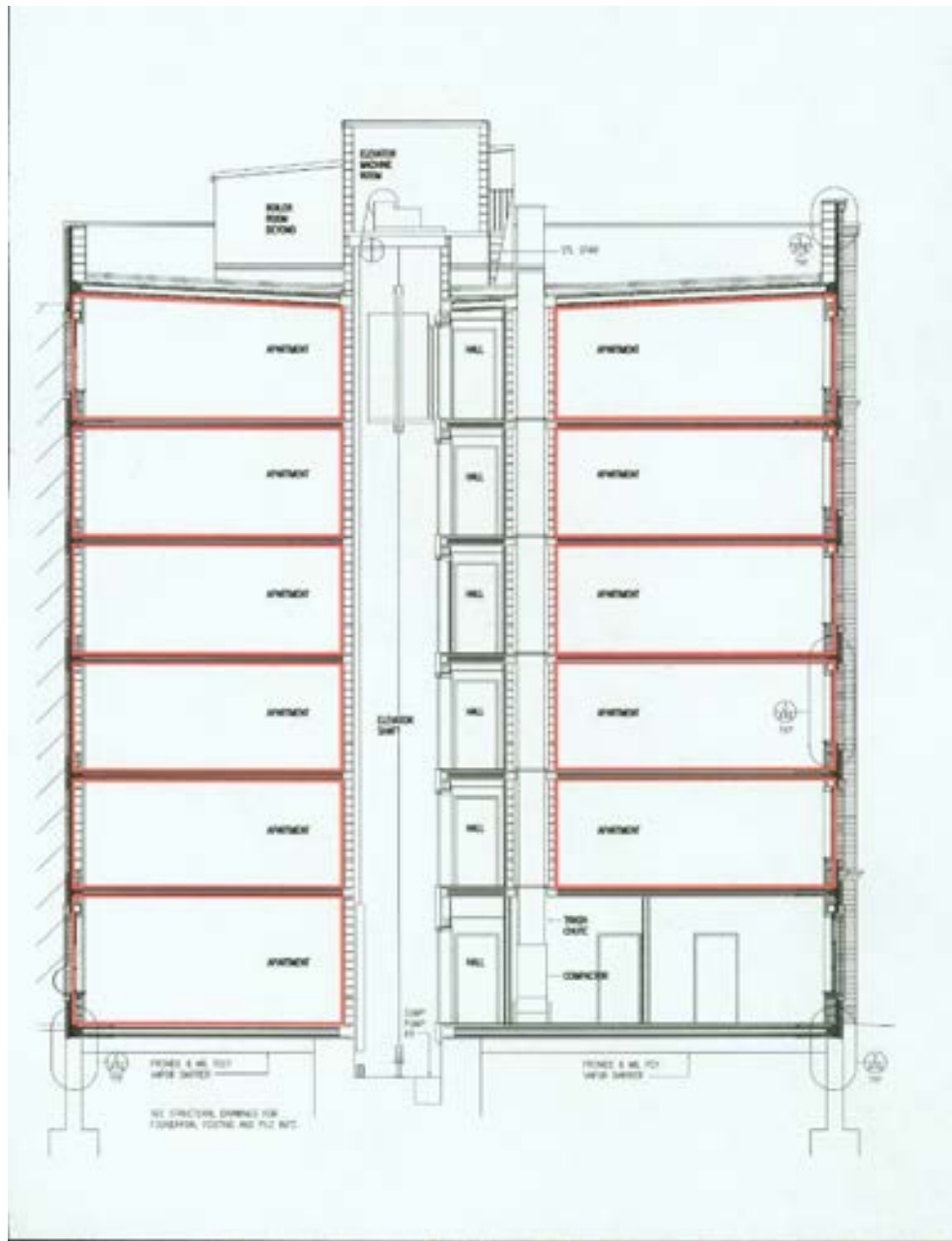
Table 1: Normalized Leakage Areas

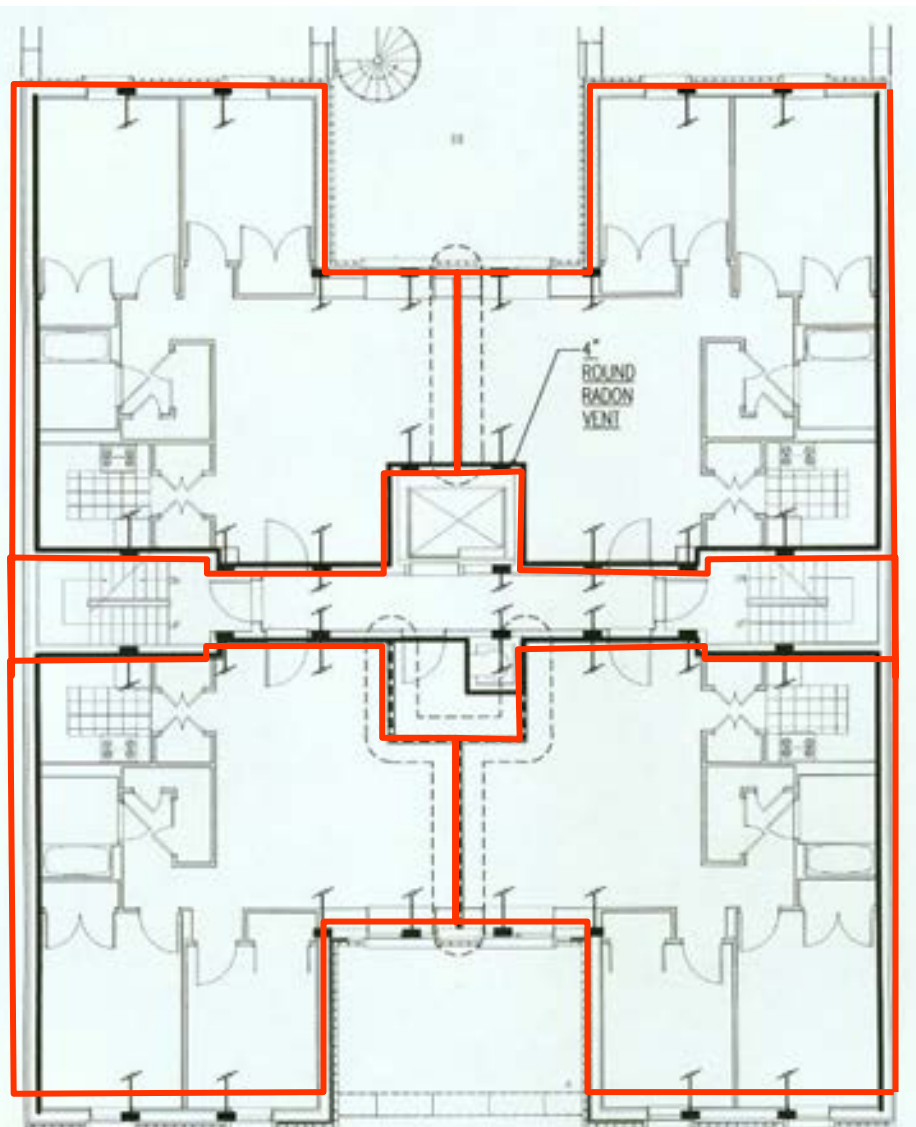
Building Area	Surface Area (sf)	CFM50 (cfm)	Normalized leakage at 75 Pa (liters/second/m ²)
Stairwell	4824	2483	3.4
Corridor 2	9490	5202	3.6
Corridor 3	9490	6783	4.7
Corridor 5	9490	6783	4.7
Unit 201	3283	1005	2.0
Unit 205	3118	894	1.9
Unit 208	4029	1267	2.1
Unit 309	4250	1263	2.0
Unit 313	4029	1264	2.1
Unit 503	4027	1405	2.3
Unit 506	4027	1340	2.2
Elevator shaft	2693	5671*	13.9

*This value was extrapolated from 2 Pa to 50 Pa using an assumed value of $n=0.65$. This extreme of extrapolation is subject to significant error.





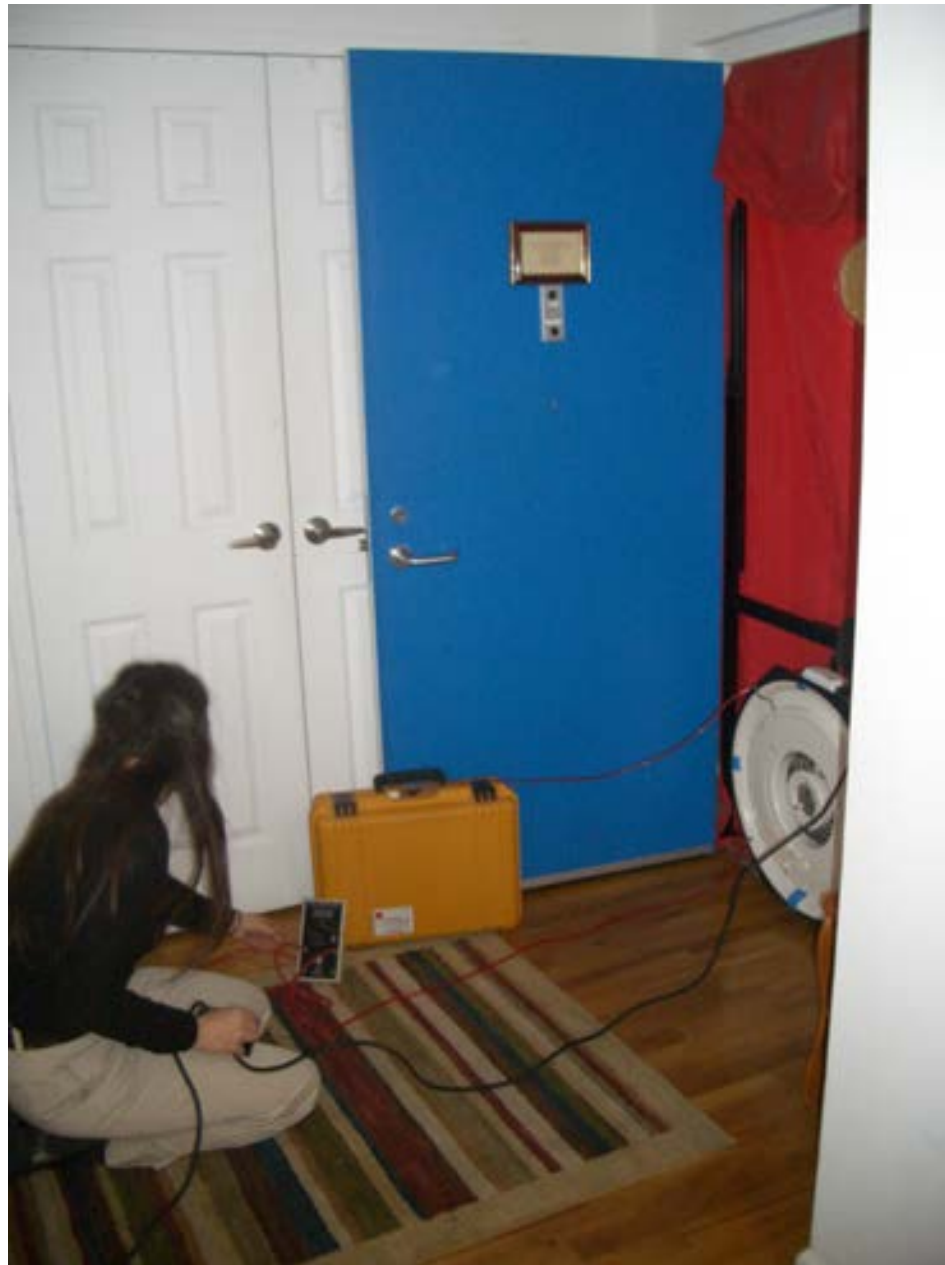


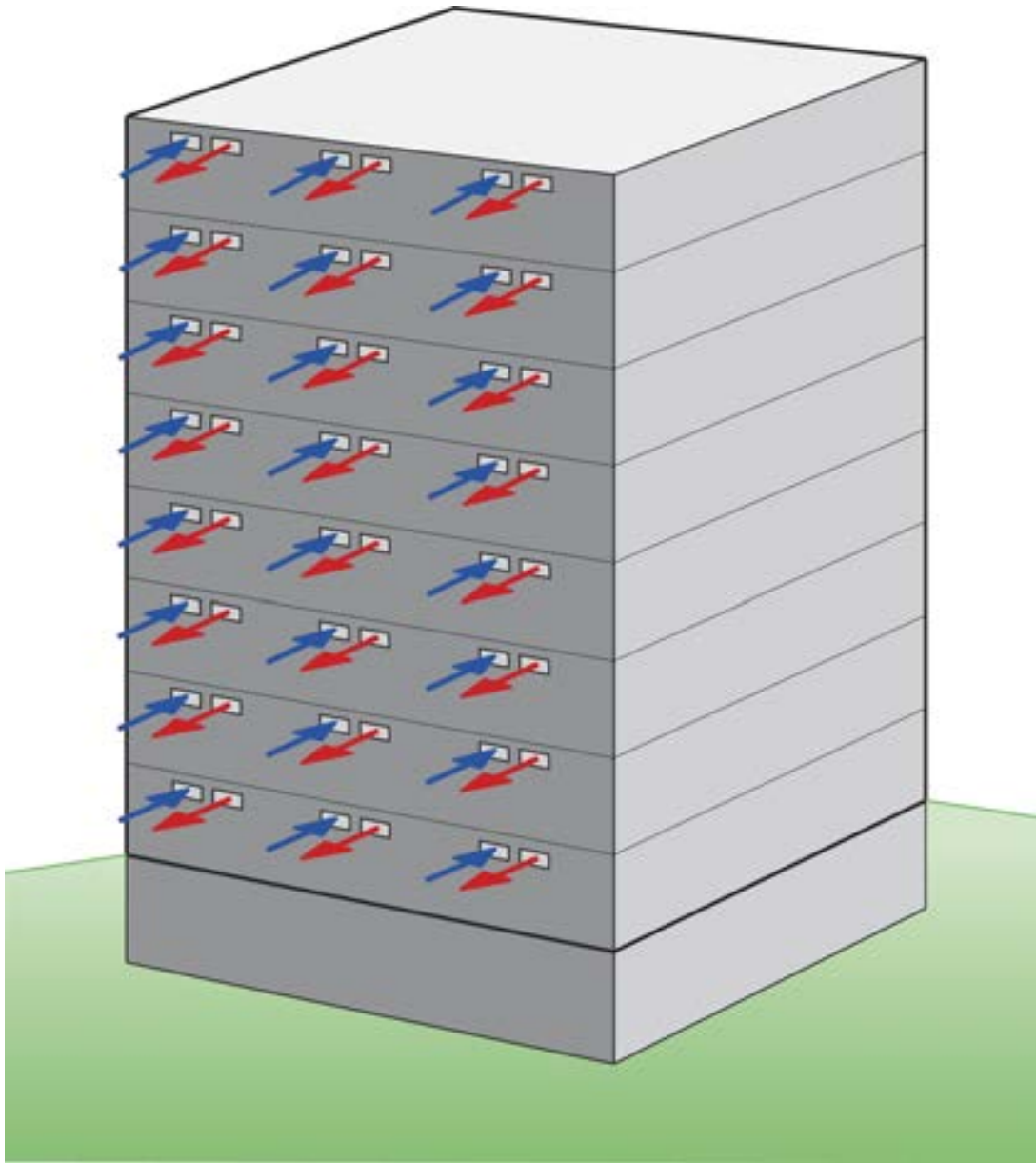


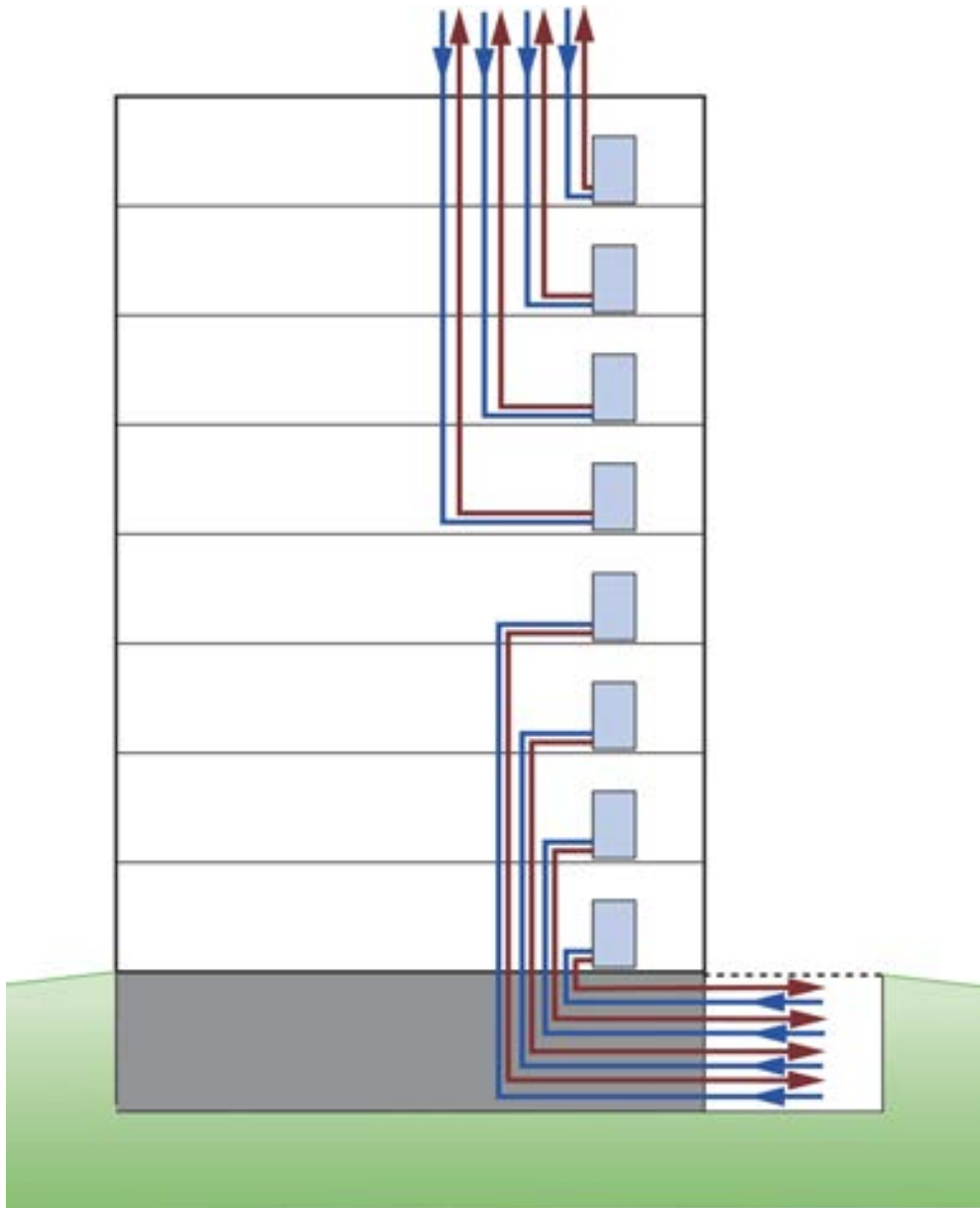
② SECOND THROUGH SIXTH FLOOR PLAN

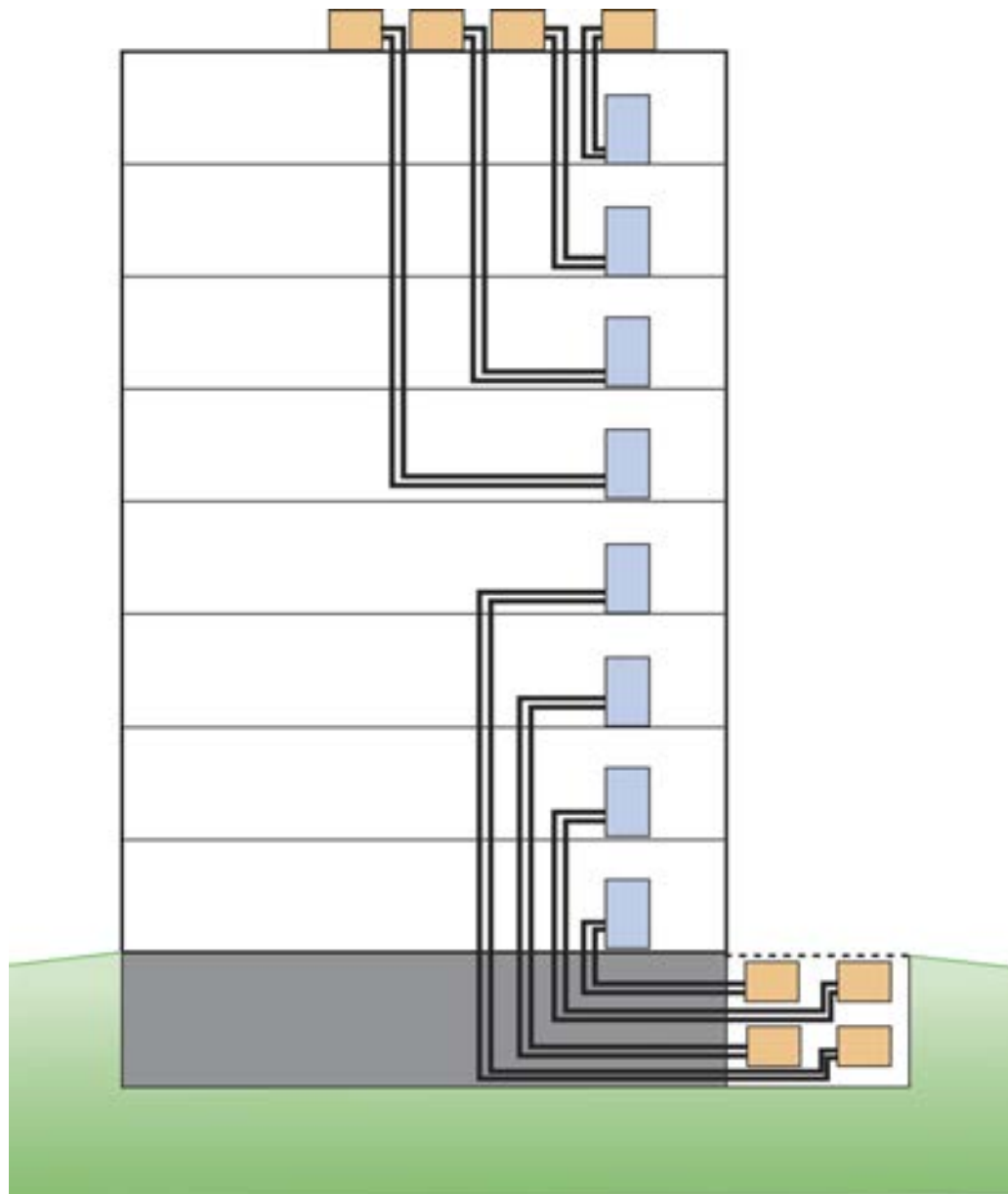


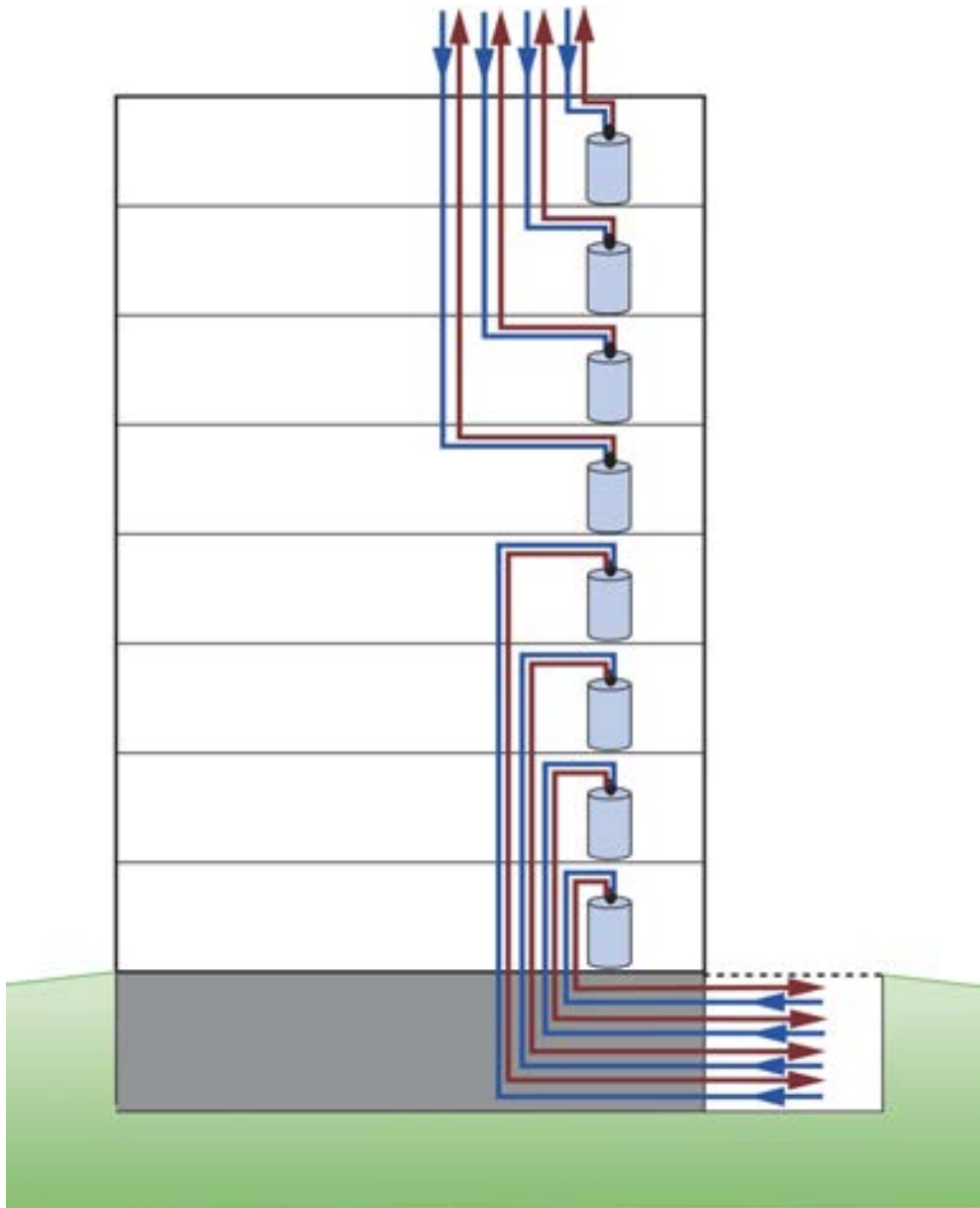
























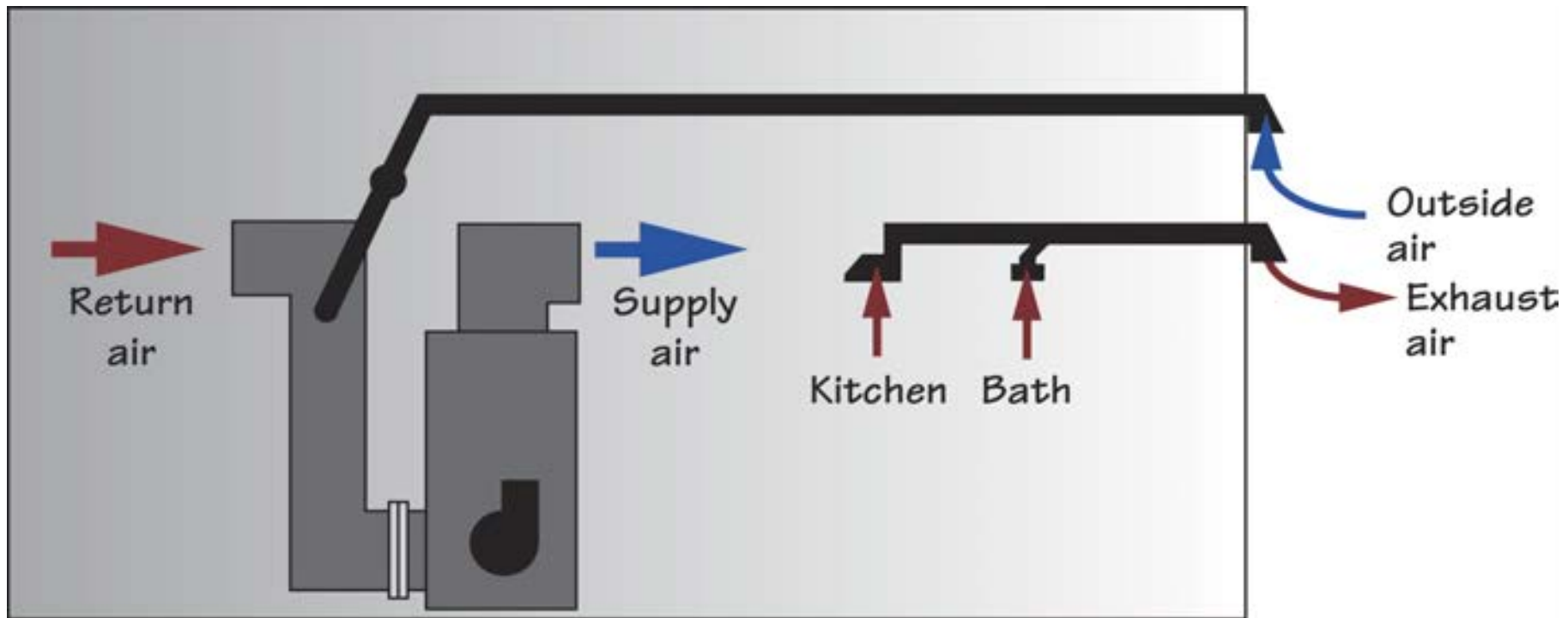


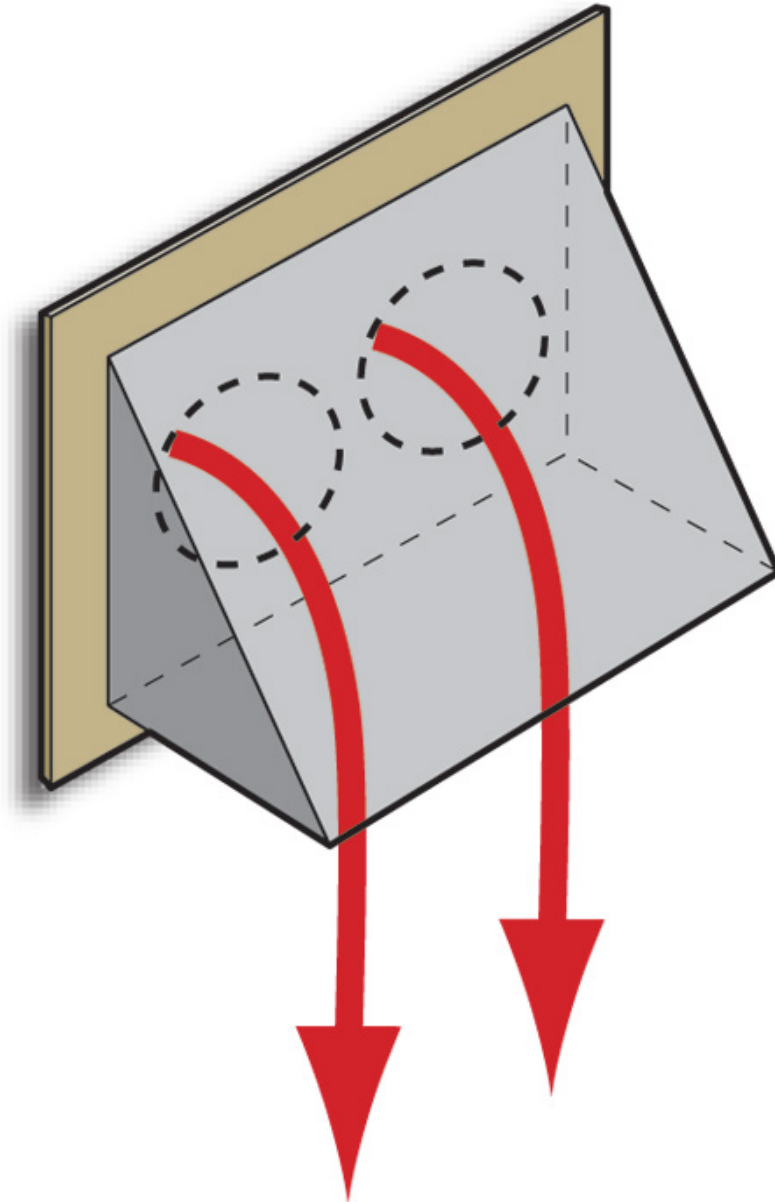


ASHRAE Standard 62.2 calls for 7.5 cfm per person plus 0.01 cfm per square foot of conditioned area

Occupancy is deemed to be the number of bedrooms plus one

Occupant Rate + Building Rate



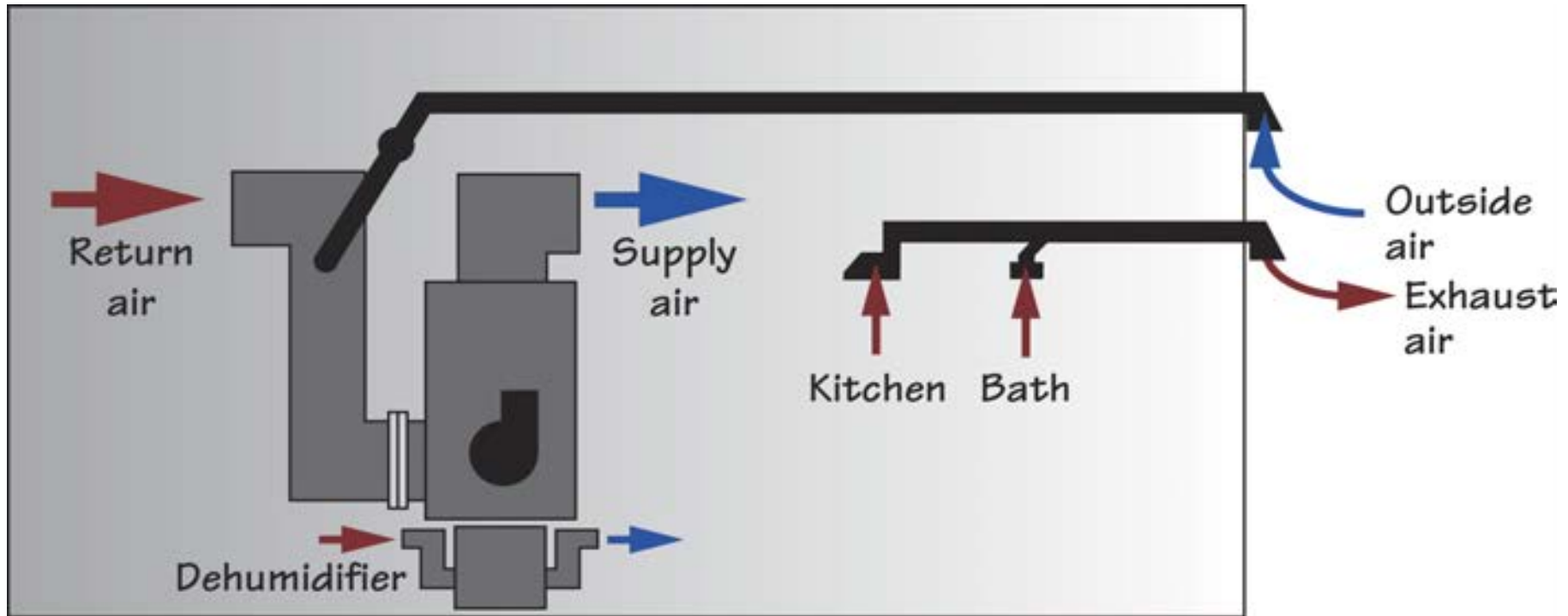


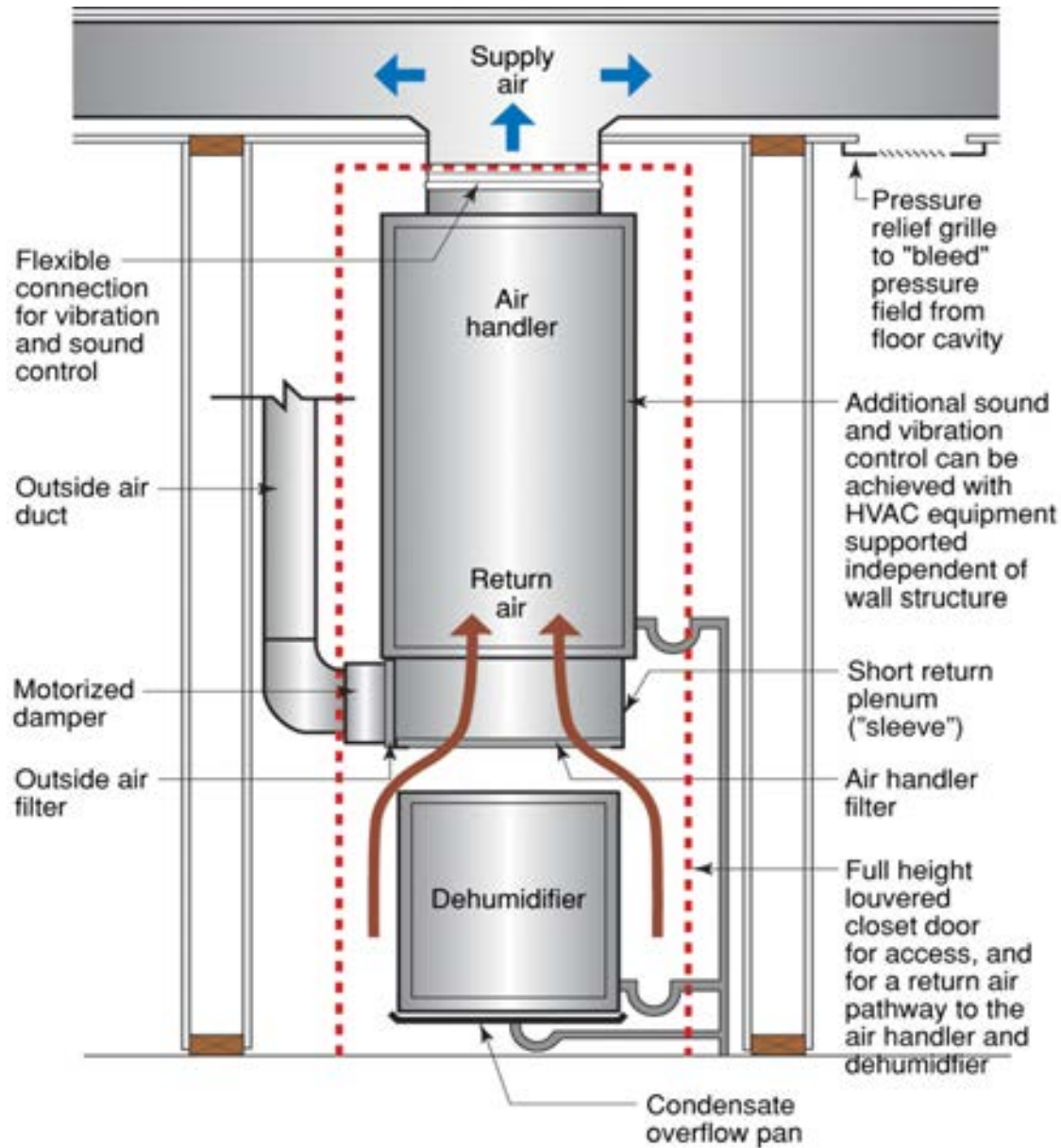


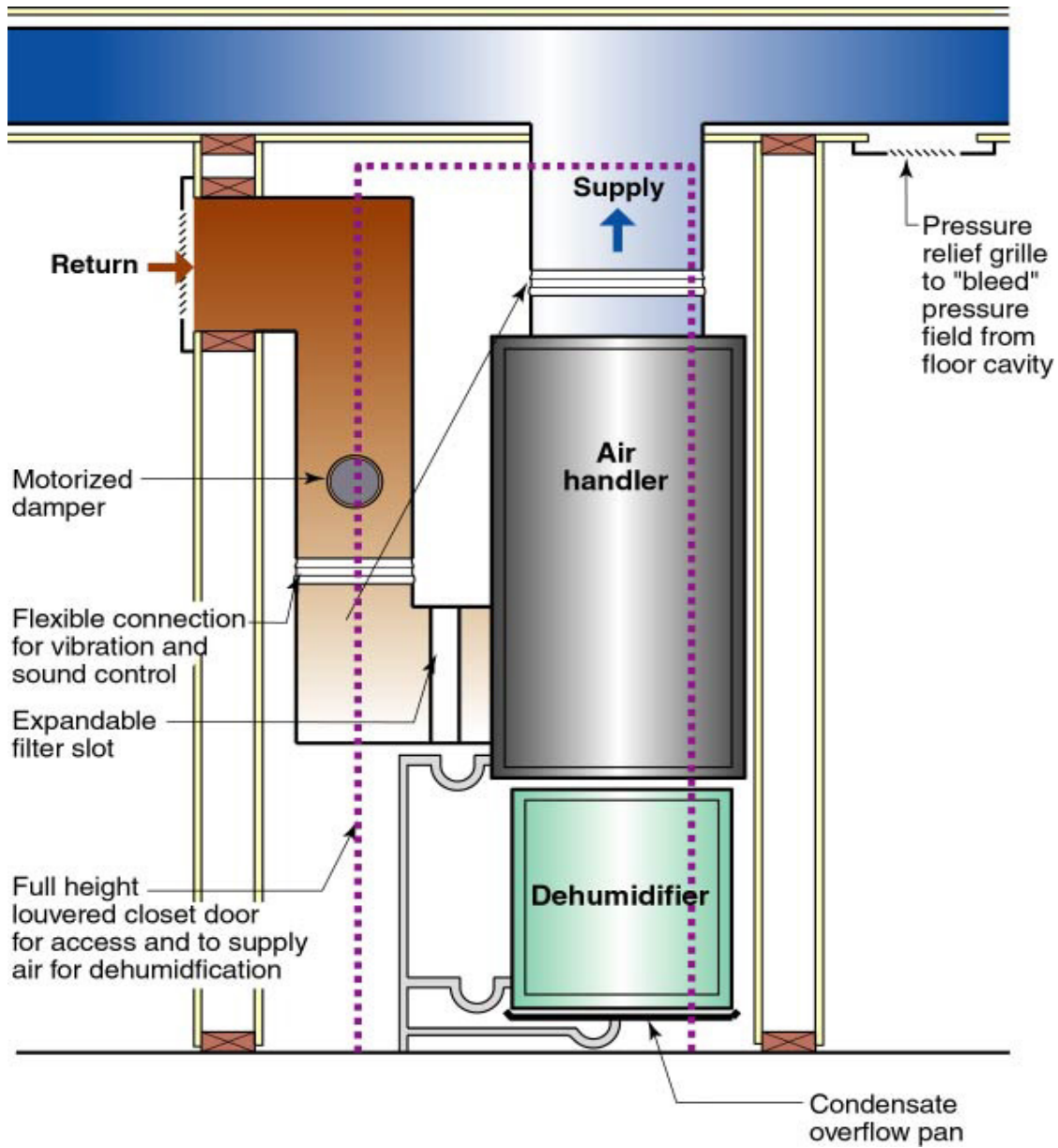










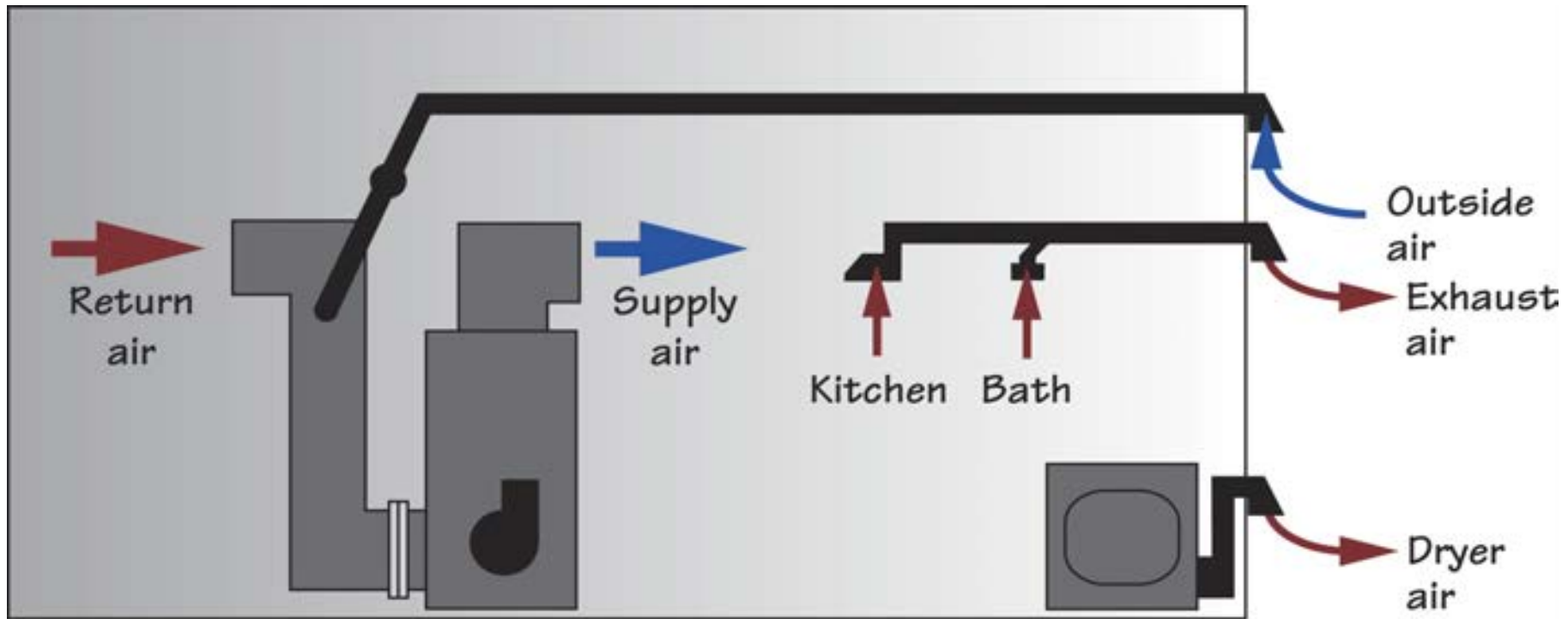




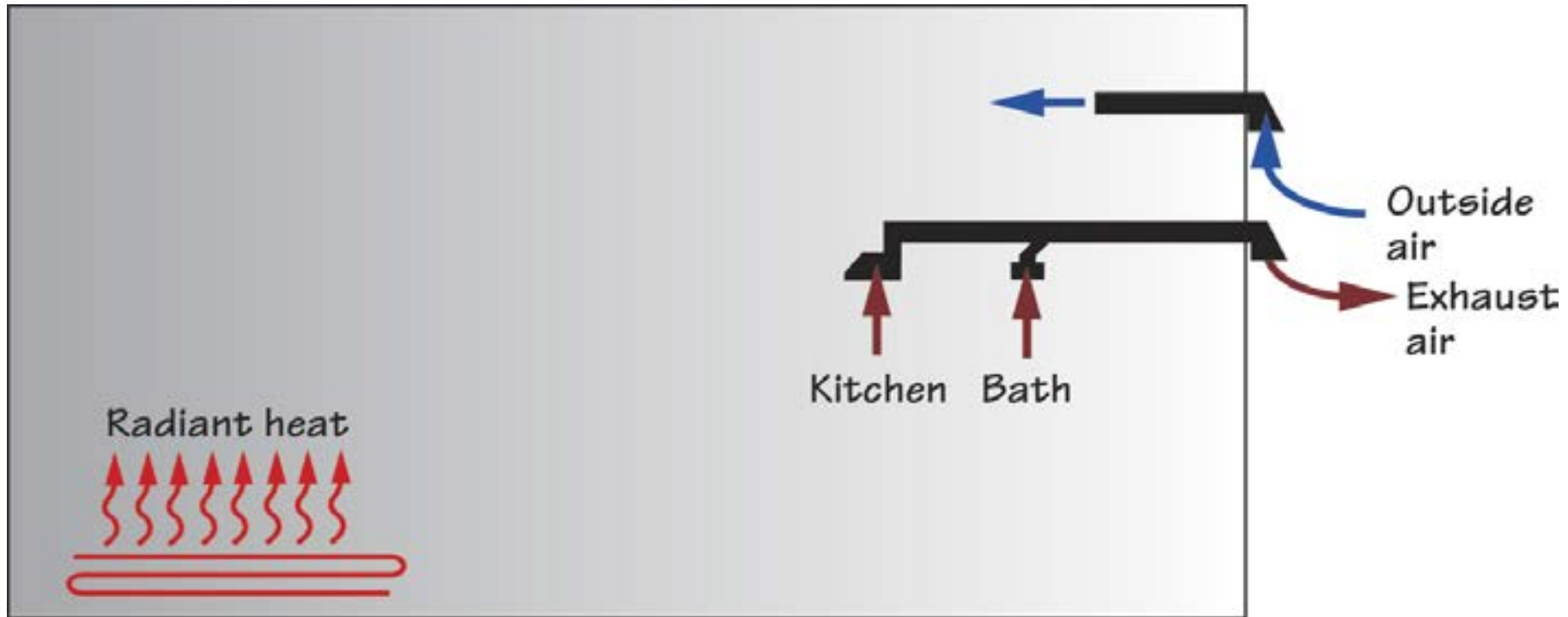


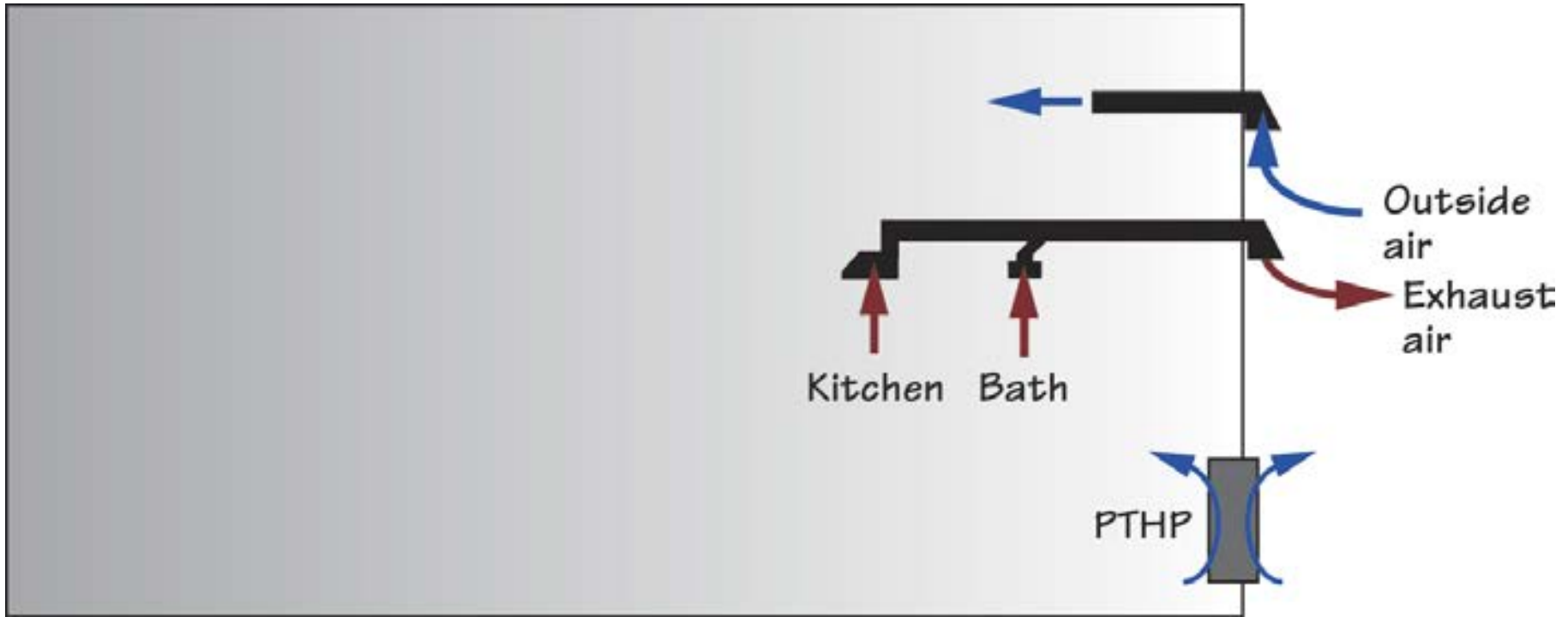


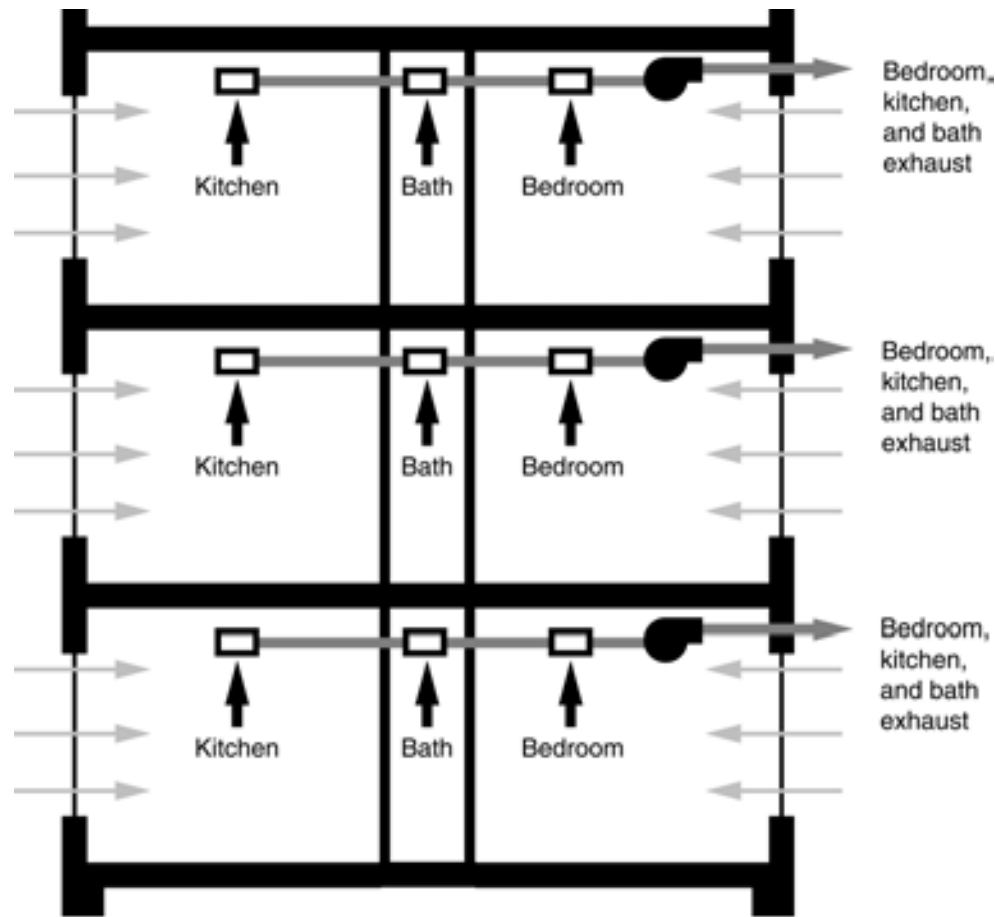










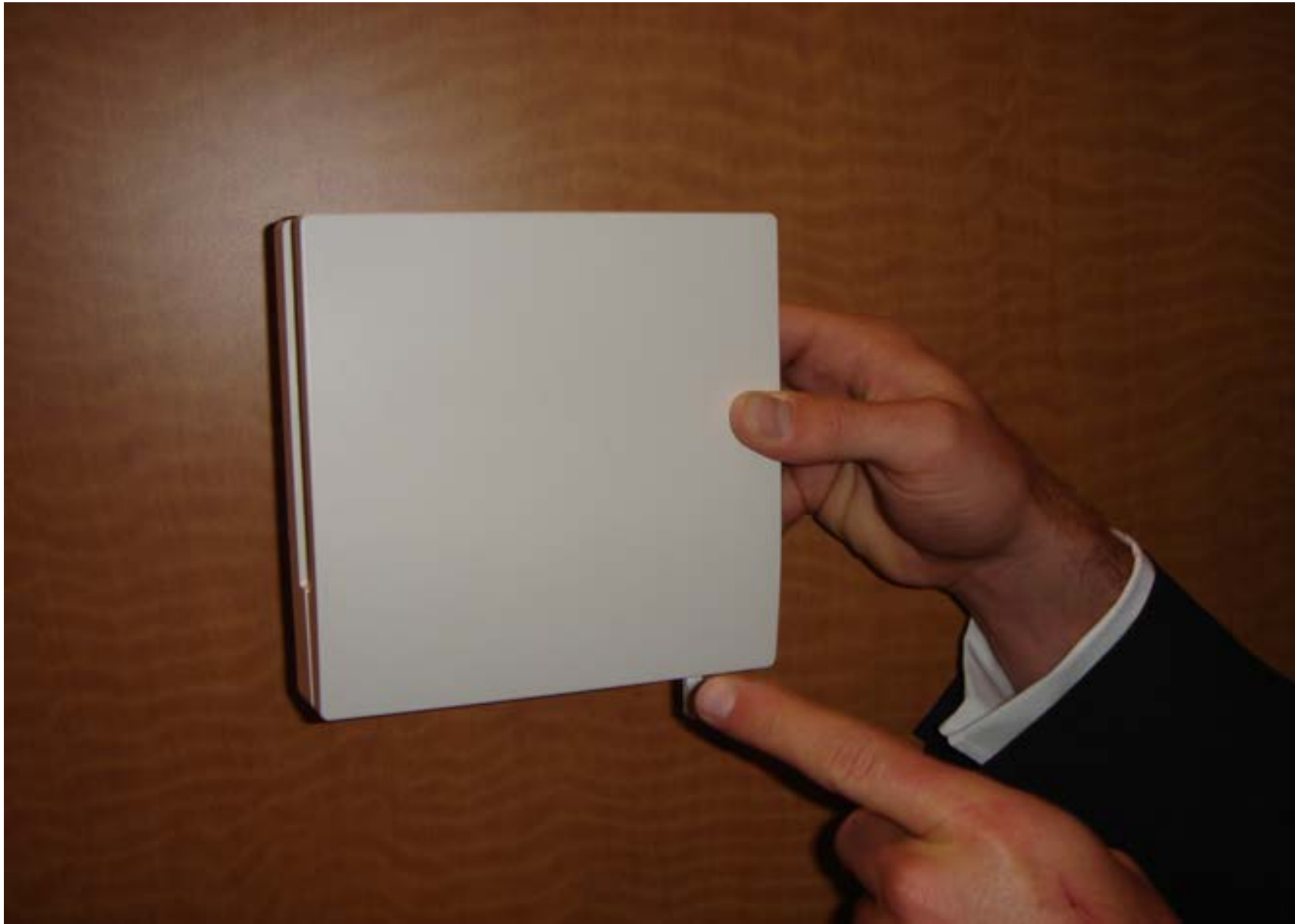


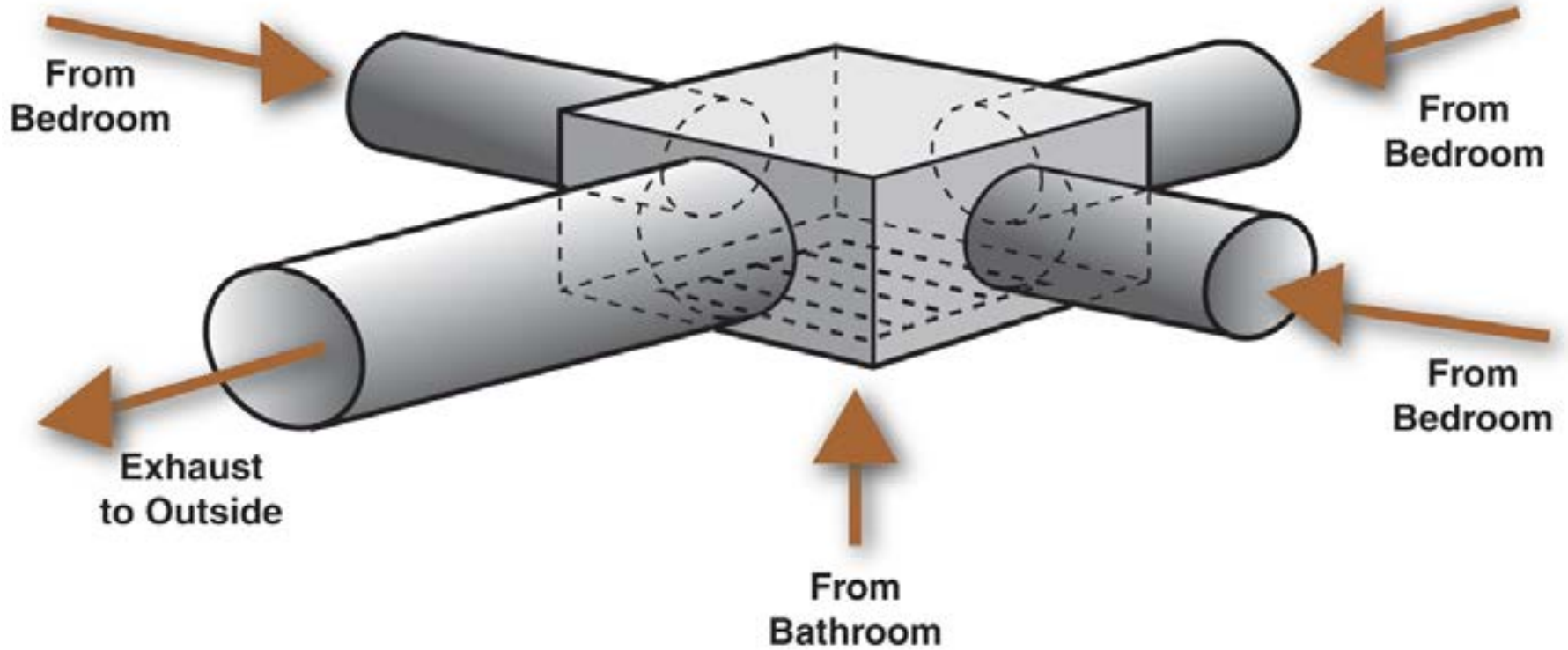
Distributed Ventilation

- Individual unit exhaust ventilation fan exhausts (during occupancy) from each bedroom, bathroom, and kitchen
- Operation of system is time of occupancy sensitive — on only when occupied

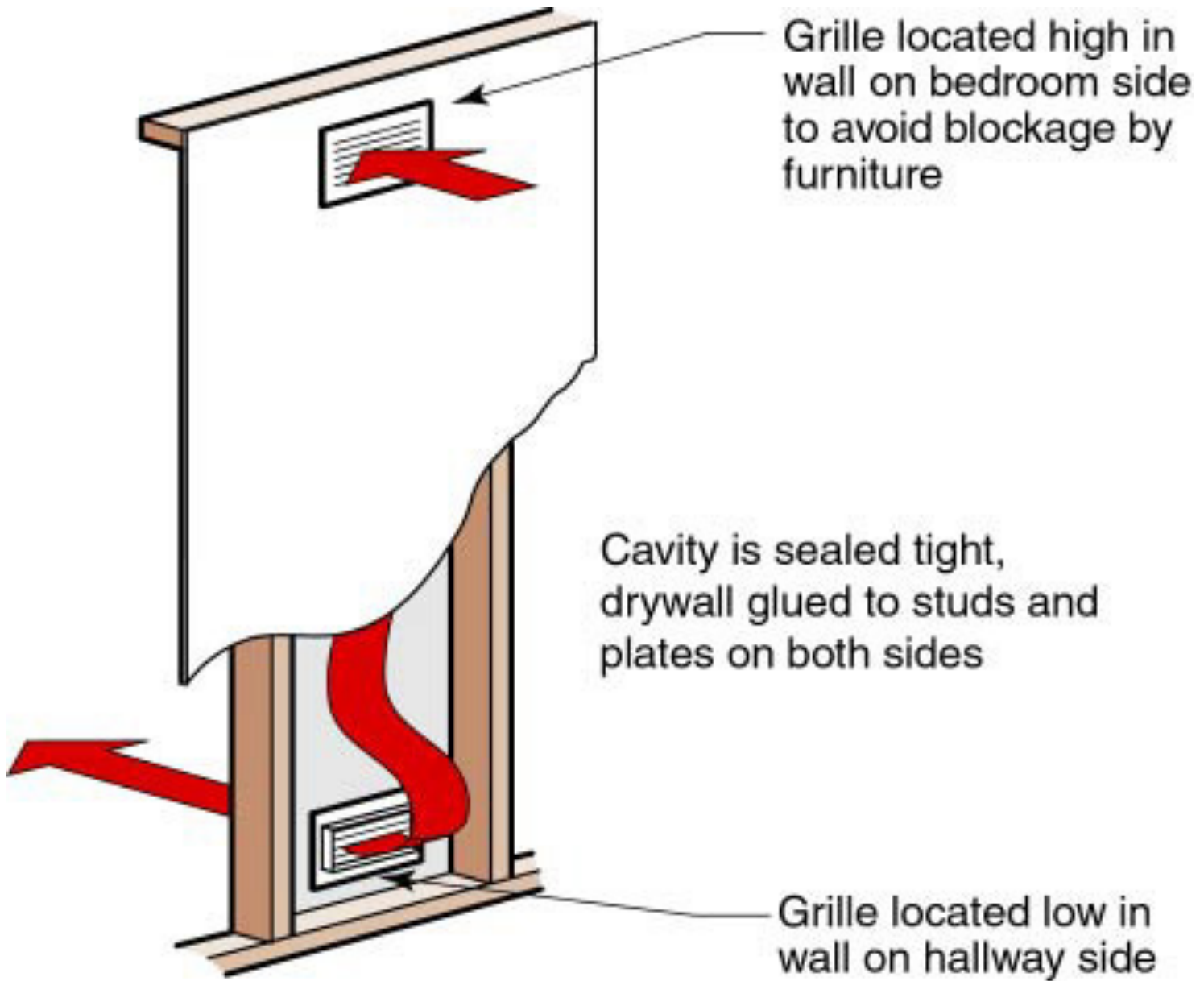


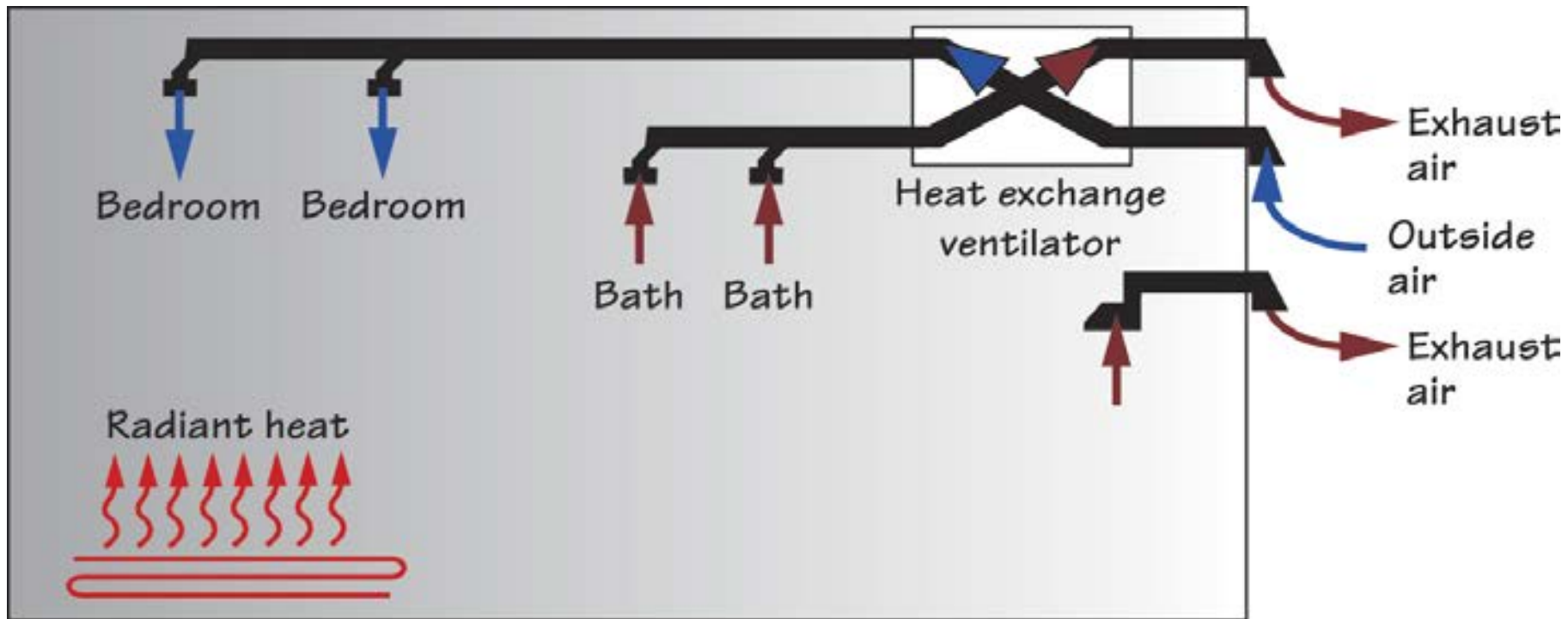




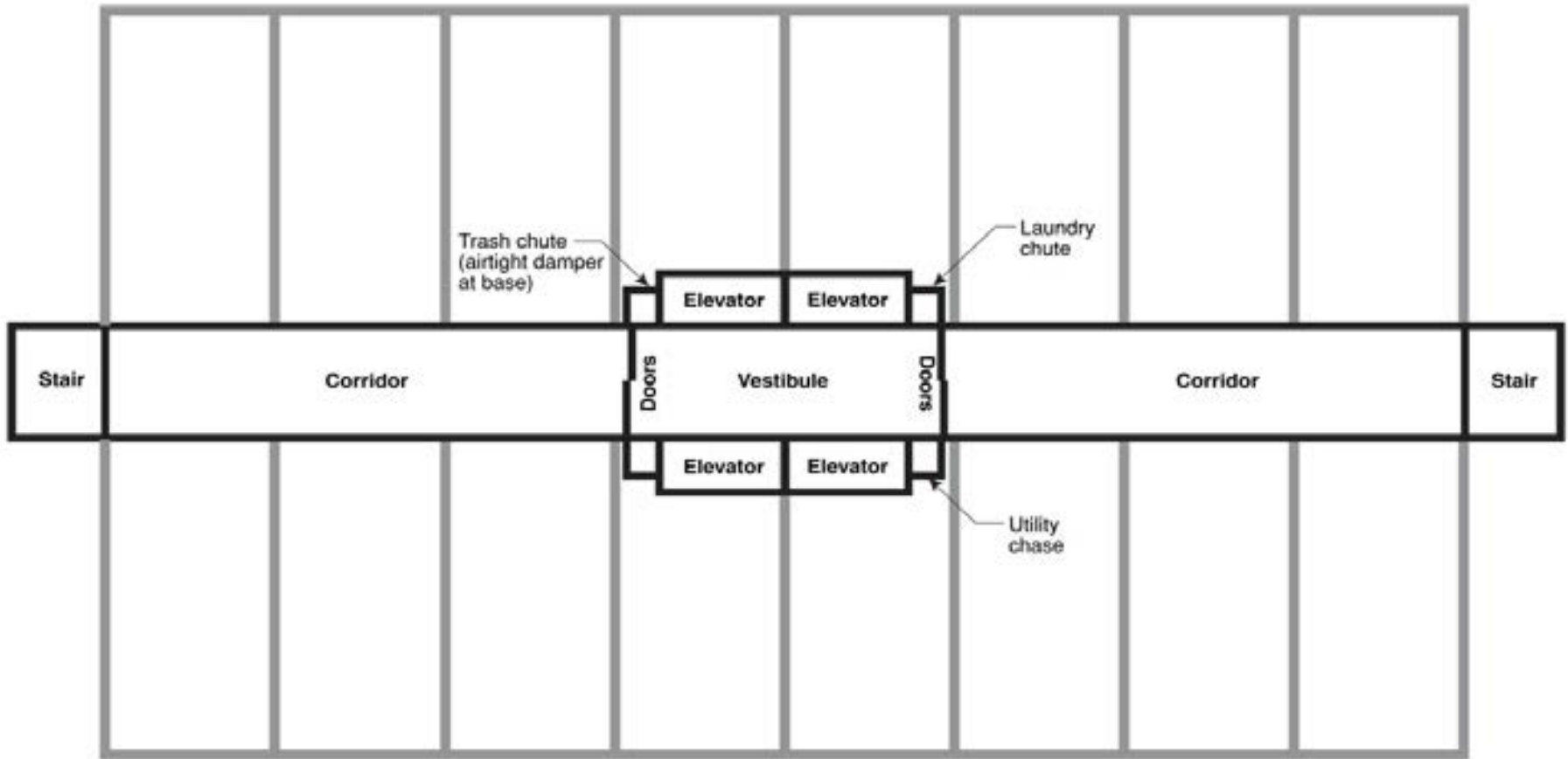








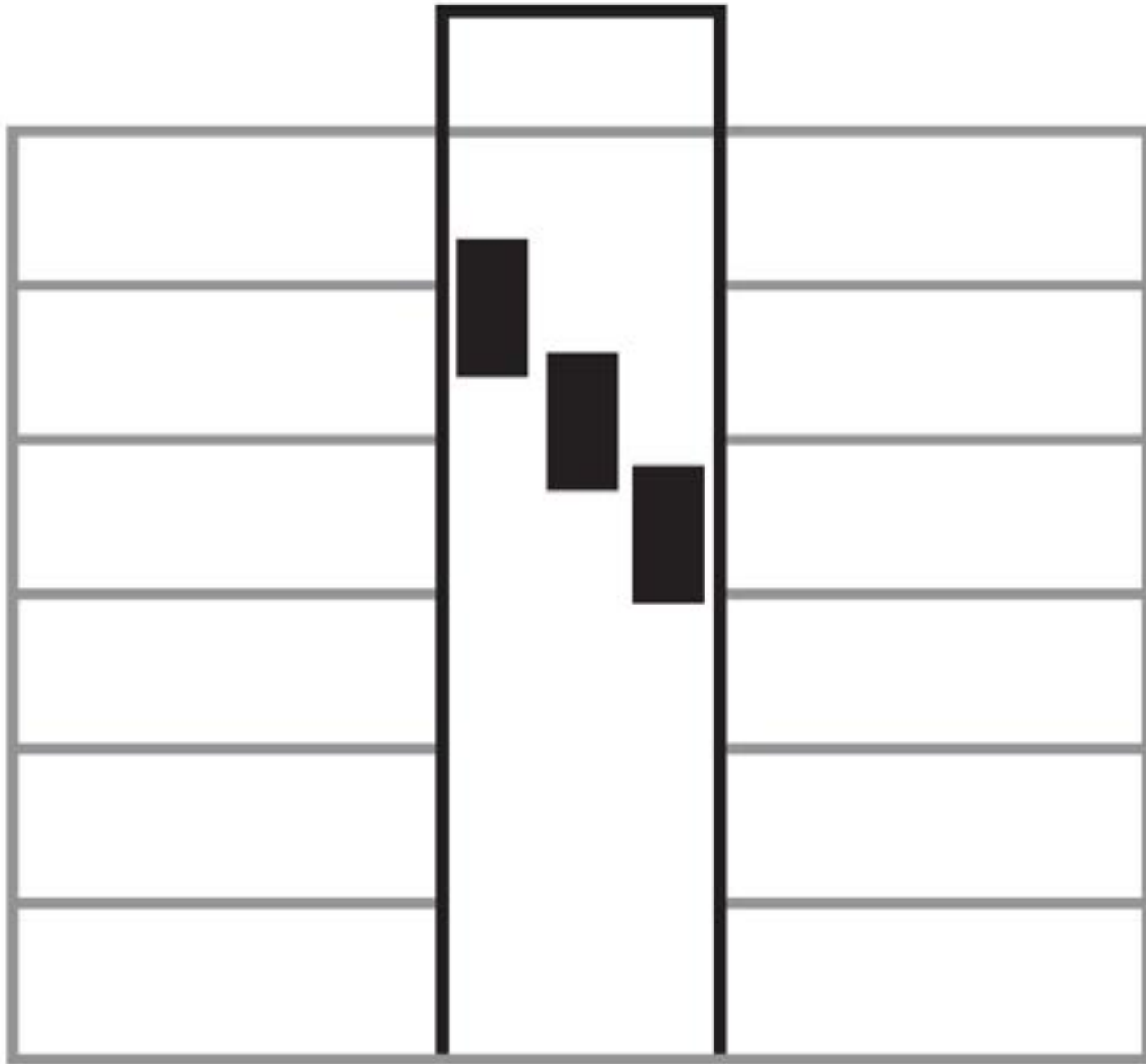


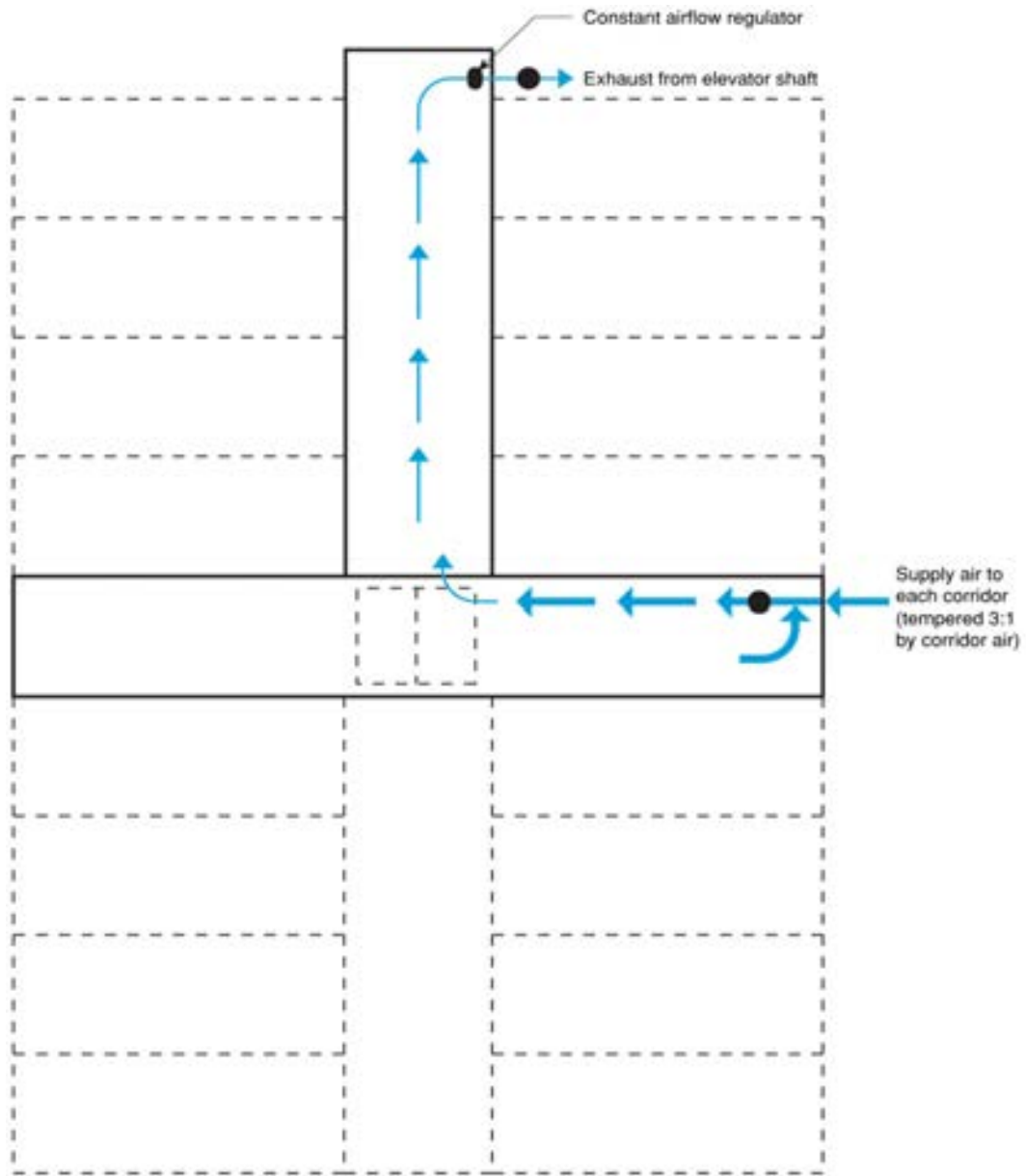


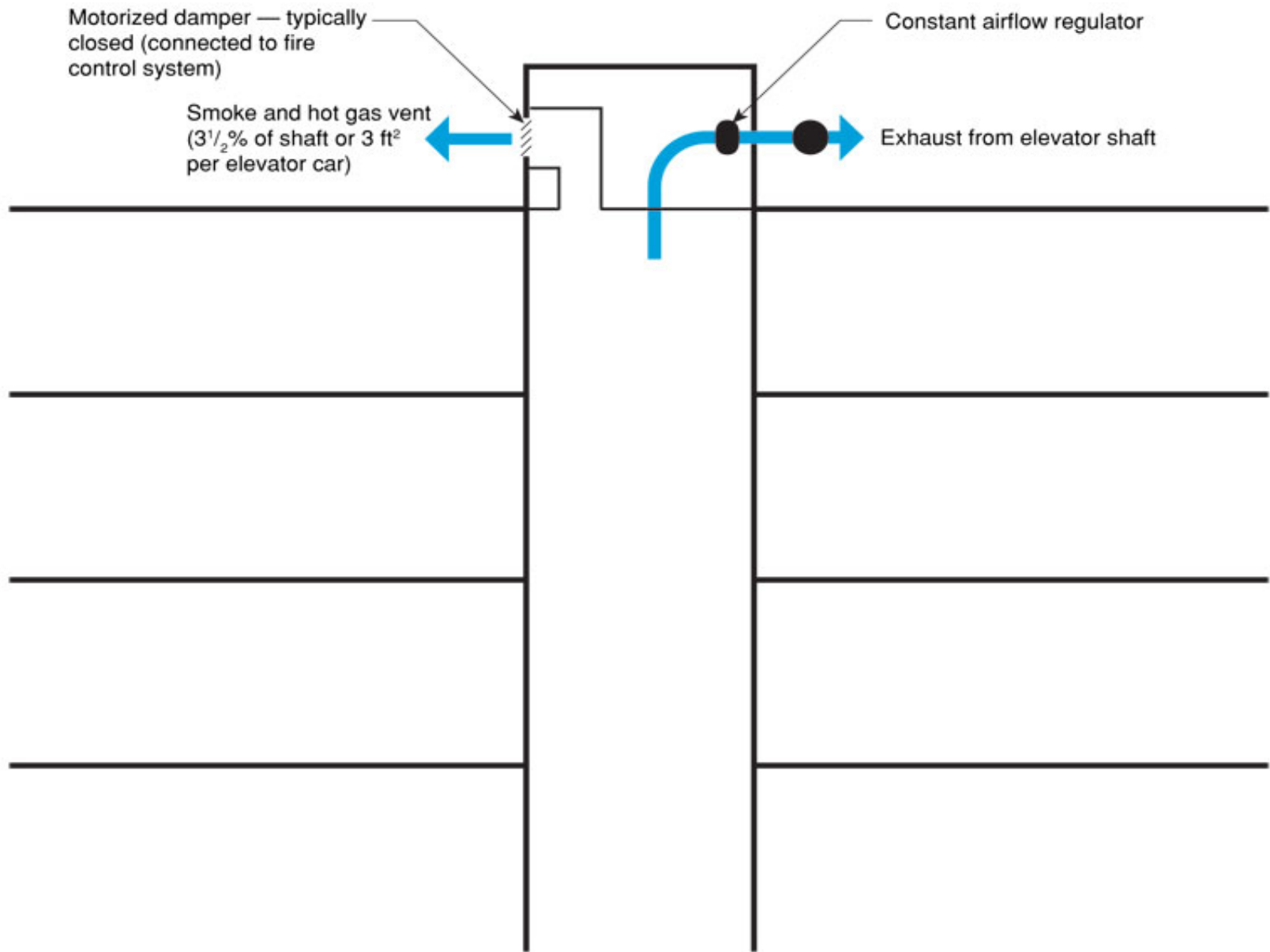


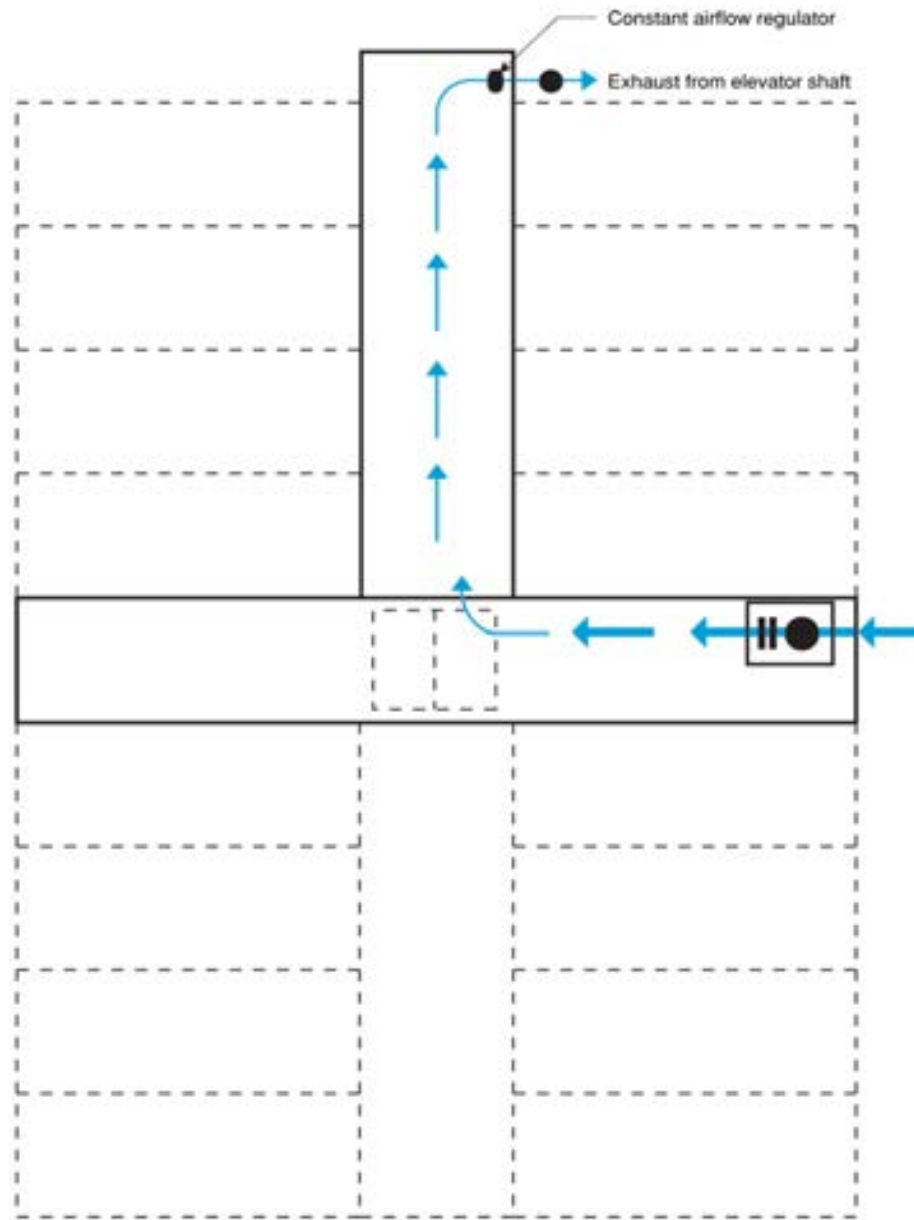


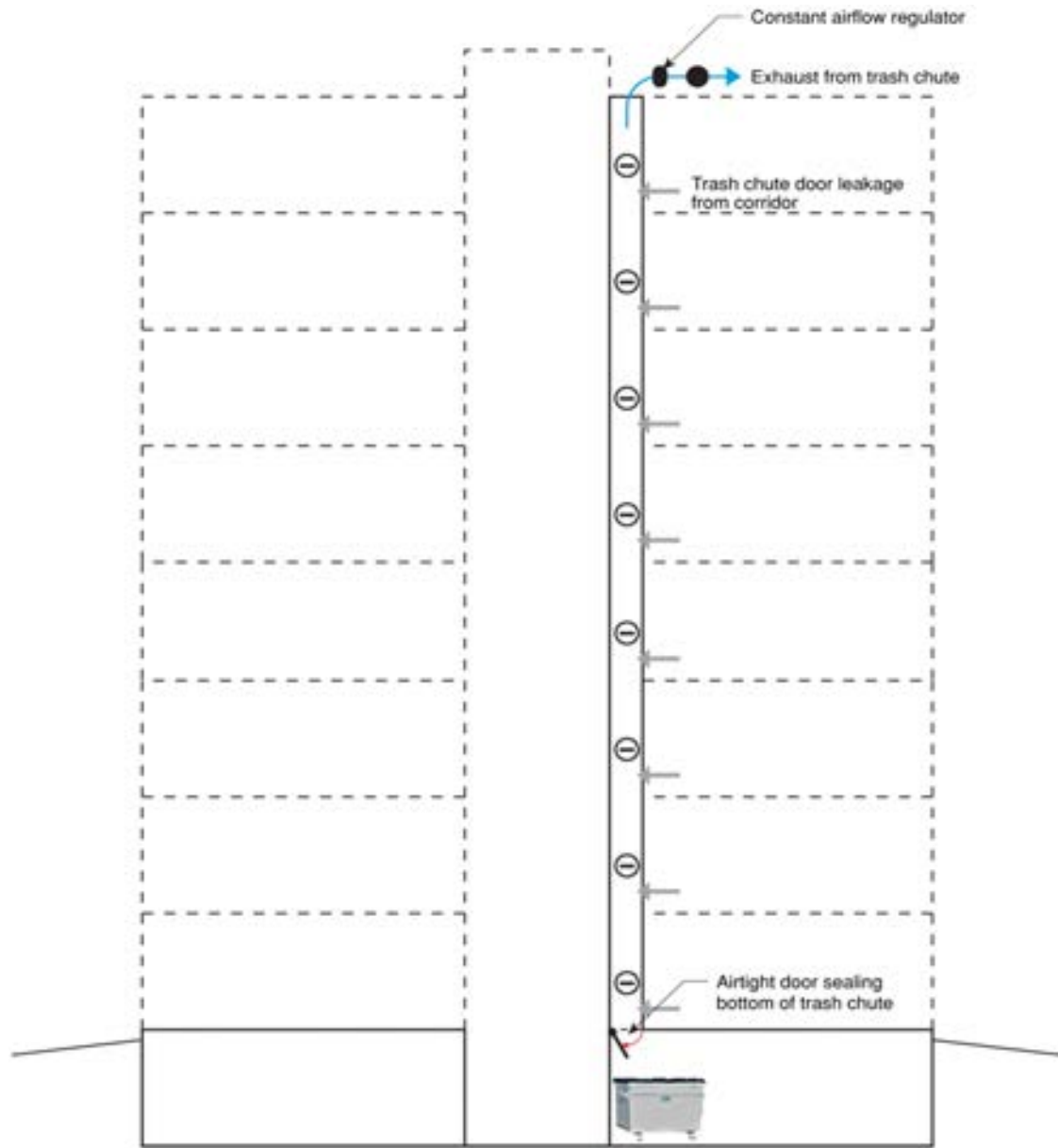












Double Facade

aka “Facadists”

Note the difference - “viva la difference”

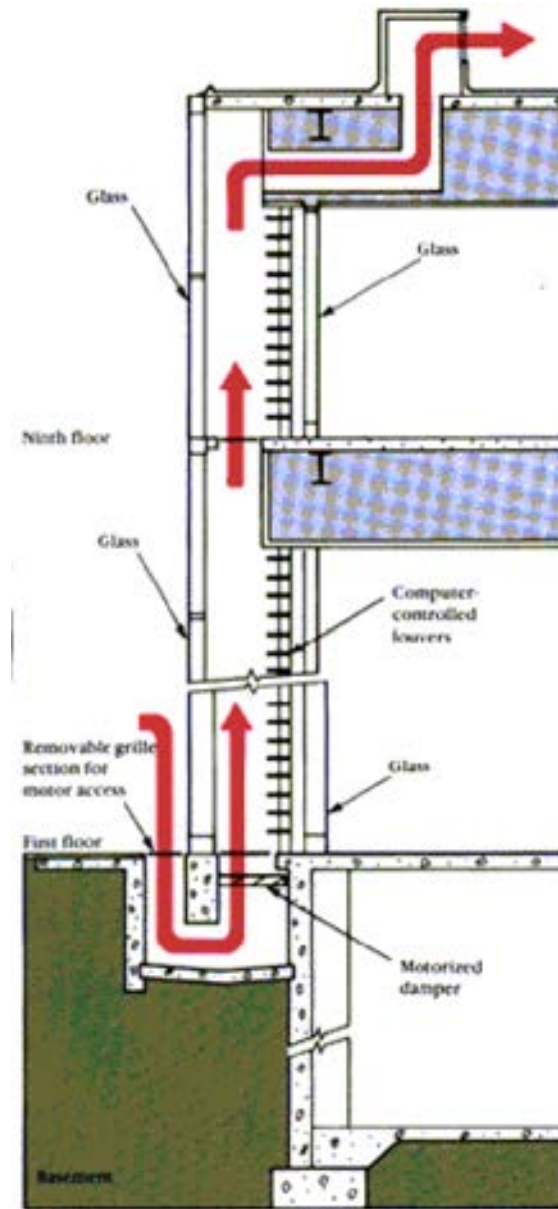
Single façade with exterior shade - good

Double façade - bad



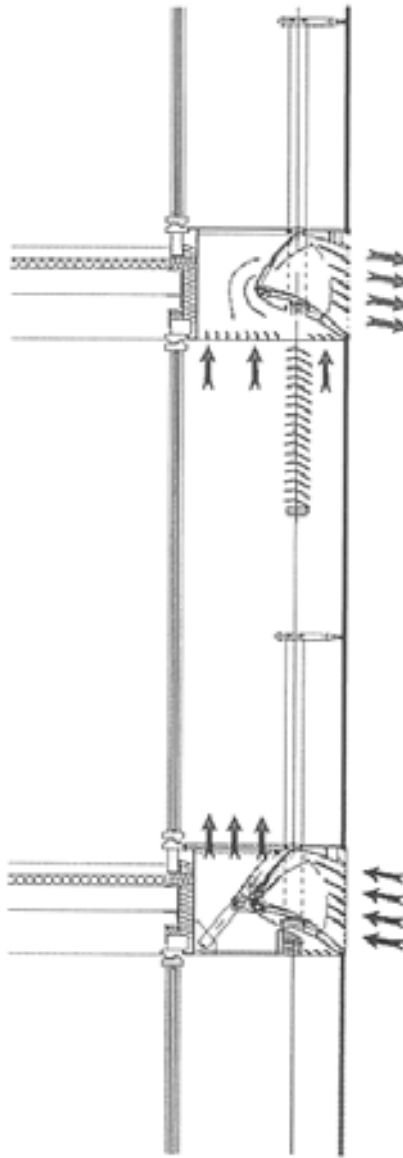












UFA...aka “Underfloor Air Plenums” - or
other dumb things I did before I became
an adult....

